

# RHODE ISLAND LOW IMPACT DEVELOPMENT SITE PLANNING AND DESIGN GUIDANCE MANUAL

MARCH 2011



Rhode Island Department of Environmental Management



Coastal Resources Management Council



# **Rhode Island Low Impact Development Site Planning and Design Guidance Manual**

**February 2011**

Written and Designed  
by

**Horsley Witten Group, Inc.**  
and  
**Scott Millar, Administrator Sustainable Watersheds**  
**Rhode Island Department of Environmental Management**

## **Acknowledgements**

An advisory committee provided invaluable input during the preparation of this guidance. Thanks to: **Eric Beck**, DEM; **Rich Blodgett**, Providence Water; **Paul Boisvert**, The Greene Consulting Group; **Jim Boyd**, CRMC; **Caitlin Chaffee**, CRMC; **Russ Chateaufneuf**, DEM; **Margarita Chatterton**, DEM; **Dave Everett**, City of Providence Planning Office; **Joe Frisella**, Frisella Engineering Inc.; **Walt Galloway**, USEPA; **Ray Goff**, Gloucester Town Planner; **Nancy Hess**, Statewide Planning Office, Department of Administration; **Ferdinand Ihenacho**, FCI Engineers Inc; **Lorraine Joubert**, URI Cooperative Extension; **Tom Kravitz**, Burrillville Town Planner; **Eugenia Marks**, Audubon Society of RI; **Colleen McCue**, Narragansett Bay National Estuarine Research Reserve; **Shannon McManus**, intern DEM; **Ernie Panciera**, DEM; **Margherita Pryor**, U.S. EPA; **Elizabeth Scott**, DEM; **Jen West**, Narragansett Bay National Estuarine Research Reserve.

This guidance manual was funded in part through the U.S. Environmental Protection Agency pursuant to the Clean Water Act Section 319 Nonpoint Source Program grants and through the National Oceanic and Atmospheric Administration pursuant to Section 306 of the Coastal Zone management Act.

**Dear Rhode Islander:**

In the past, stormwater management was primarily an engineering exercise to collect and dispose of runoff as quickly as possible. The new *Rhode Island Stormwater Design and Installation Standards Manual* changes stormwater management to include more creative planning and site design as well as better engineering practices in keeping with the requirements of the Smart Development for a Cleaner Bay Act of 2007.

The new manual requires Low Impact Development (LID) for all sites, representing a fundamental shift in how development projects are planned and designed. LID is a more comprehensive approach to managing stormwater that uses site planning and design techniques that store, infiltrate, evaporate, and detain runoff as close as possible to the point where precipitation reaches the ground.

LID can be used to accommodate growth while reducing the environmental impact of site development. Many of the LID concepts employ non-structural on-site treatment that can reduce the cost of infrastructure while maintaining or even increasing the value of the property relative to conventionally-designed developments. In the past the landscape was altered significantly to fit the style of development, whereas this LID process is reversed so that development is designed to fit the landscape and its natural features.

LID encourages the use of local planning and community land use authority to avoid and reduce the impacts of stormwater runoff. The *Rhode Island Low Impact Development Site Planning and Design Guidance Manual* was developed to provide examples for local planning officials of how their ordinances may be amended to avoid and reduce the impacts from development and encourage the more effective implementation of LID practices. These recommended site planning and design techniques can also help preserve community character, reduce flooding, and reduce municipal operation and maintenance costs. The intent is to assist our community partners in accommodating desirable growth without sacrificing the environment or the quality of life that Rhode Islanders enjoy.

RI DEM and CRMC are committed to providing Rhode Island communities with the assistance they need to plan for growth while protecting and restoring the environment.

Sincerely,



Janet Coit, Director  
Department of Environmental Management



Grover Fugate, Executive Director  
Coastal Resources Management Council



# TABLE OF CONTENTS

<b>1. Introduction</b>	<b>1</b>
<b>2. Conservation Development</b>	<b>7</b>
<b>3. Riparian Buffer Standards</b>	<b>18</b>
<b>4. Site Clearing and Grading Standards</b>	<b>38</b>
<b>5. LID Roadway Design</b>	<b>51</b>
Travel Way (Pavement) Width	51
Right-of-Way (ROW) Width	55
Driveway Design	58
Curb Requirements	63
Sidewalk Layout and Design	66
Length and Radius of Cul-de-sacs	68
Intersection Geometry	71
Summary	73
<b>6. LID Parking Guidance</b>	<b>78</b>
Parking Ratios	78
Shared Parking	82
Off-Site Parking Allowances	84
Stall and Aisle Geometry	85
Parking Lot Landscaping	87
Summary	90
<b>7. LID and Compact Development</b>	<b>95</b>
<b>8. LID Landscaping</b>	<b>108</b>
<b>9. Special Purpose Ordinances</b>	<b>120</b>
Impervious Cover Ordinance	120
Erosion and Sediment Control Ordinance	124
Review and Inspection Fees	128
Stormwater Utility Districts	133
<b>Appendix A</b>	<b>A-i</b>
<b>Appendix B</b>	<b>B-i</b>





## 1.0 INTRODUCTION

This guide was written as a companion to the recently revised Rhode Island Stormwater Design and Installation Standards Manual (the RI Stormwater Manual). The primary purpose of this guide is to provide communities with the specific guidance they will need to revise their applicable land use regulations to avoid and reduce the impacts of stormwater runoff and to effectively comply with the RI Stormwater Manual's Minimum Standard 1: LID (Low Impact Development) Site Planning and Design Strategies.

The RI Stormwater Manual was updated to comply with Rhode Island General Law, Section 45, Chapter 61.2, entitled "The Smart Development for a Cleaner Bay Act of 2007" (the Bay Act of 2007). The Bay Act states that "stormwater, when not properly controlled and treated, causes pollution of the waters of the state..." and "development often results in increased stormwater runoff by increasing the size and number of paved and other impervious surfaces..." The Bay Act of 2007 required the Rhode Island Department of Environmental Management (RI DEM) and the Rhode Island Coastal Resources Management Council (RI CRMC) to amend the 1993 Stormwater Design and Installation Standards Manual to:

- a) Maintain groundwater recharge to predevelopment levels;
- b) Maintain post-development peak discharge rates to not exceed pre-development rates; and
- c) Use LID techniques as the primary method of stormwater control to the maximum extent practicable.

**Figure 1-1 Narragansett Bay.**



*Stormwater runoff, when not properly controlled and treated, carries pollutants from land surfaces and roadways into water bodies, such as Narragansett Bay, rivers, streams, ponds, and drinking water aquifers threatening public health, aquatic ecosystems, and recreational and aesthetic resources. Proper stormwater management, including the use of LID techniques, is needed in order to protect these critical resource areas. ([www.visitrhodeisland.com](http://www.visitrhodeisland.com))*

To effectively manage the impacts of stormwater and prevent adverse impacts to flood storage capacity, water quality, and habitat, as well as meet the requirements of the Bay Act of 2007, the RI CRMC and RI DEM updated the 1993 Stormwater Design and Installation Standards Manual. The Manual has been revised to reflect current science and engineering practice concerning stormwater management and to incorporate LID methods throughout. The revised RI Stormwater Manual provides guidance for stormwater management on new development and redevelopment projects and, most importantly, incorporates LID as

the “industry standard” for all sites, representing a fundamental shift in how development projects are planned and designed.

The RI Stormwater Manual establishes 11 required minimum stormwater management standards for development and redevelopment projects. The first minimum standard is compliance with LID site planning and design strategies. This standard is as follows:

*LID site planning and design strategies must be used to the maximum extent practicable in order to reduce the generation of the water runoff volume for both new and redevelopment projects.... If full compliance is not provided, an applicant must document why key steps in the process could not be met and what is proposed as mitigation.*

Minimum Standard 1 establishes a process for measuring compliance with appropriate LID site planning and design and requires that the site planning process be formally documented. The process is categorized by three primary goals that have associated design objectives:

### **(1) Avoid Impacts**

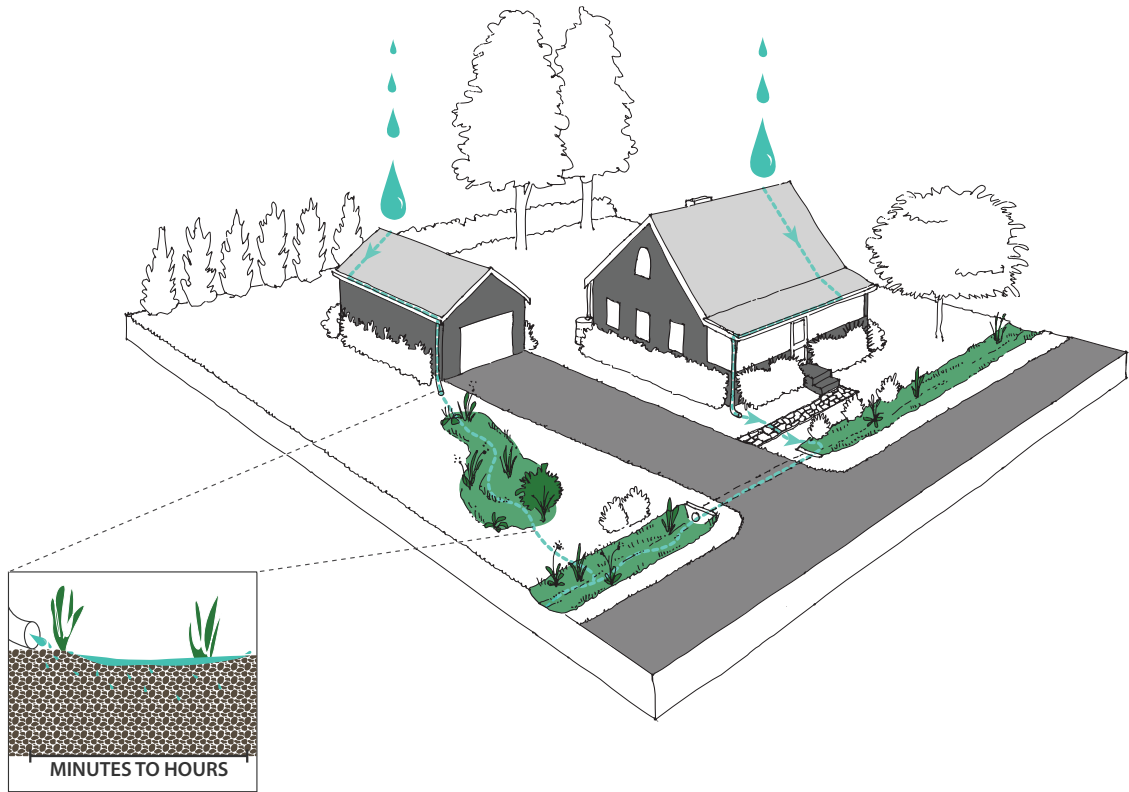
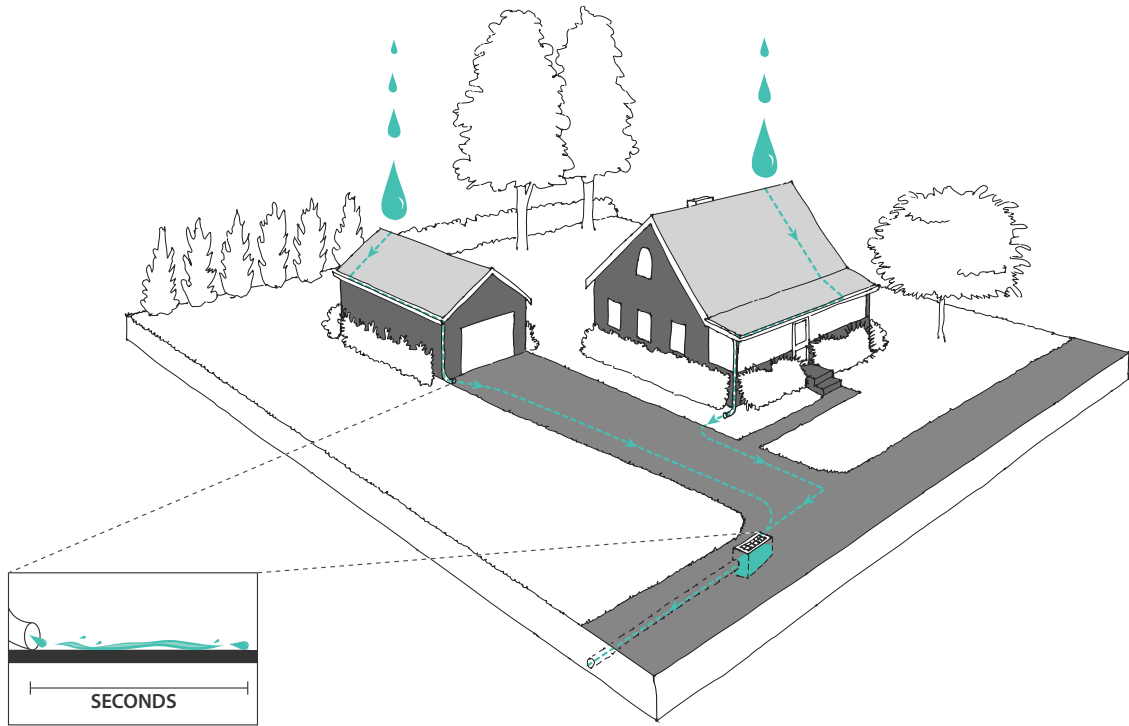
- Protect as much undisturbed open space as possible to maintain pre-development hydrology and allow precipitation to naturally infiltrate into the ground;
- Maximize the protection of natural drainage areas, streams, surface waters, wetlands, and jurisdictional wetland buffers;
- Minimize land disturbance, including clearing and grading, and avoid areas susceptible to erosion and sediment loss; and
- Minimize soil compaction and restore soils that were compacted due to construction activities or prior development.

### **(2) Reduce Impacts**

- Provide low-maintenance, native vegetation that encourages water retention and minimizes the use of lawns, fertilizers, and pesticides;
- Minimize impervious surfaces; and
- Match or increase time of concentration from pre-construction to post-construction, where “time of concentration” means the time it takes for runoff to travel from the hydraulically most distant point of the drainage area to the point of interest within a watershed (Figure 1-2).



**Figure 1-2 Designing to Increase Time of Concentration.**



*Site design techniques should provide opportunities to slow the flow of stormwater by routing storm flow pathways through vegetation and LID management practices. (HW graphic)*

### (3) Manage Impacts at the Source

- Infiltrate precipitation as close as possible to the point it reaches the ground using vegetated conveyance and treatment systems (See Figure 1-3);
- Break up or disconnect the flow of runoff over impervious surfaces; and
- Provide source controls to prevent or minimize the use or exposure of pollutants into stormwater runoff at the site in order to prevent or minimize the release of those pollutants into stormwater runoff.

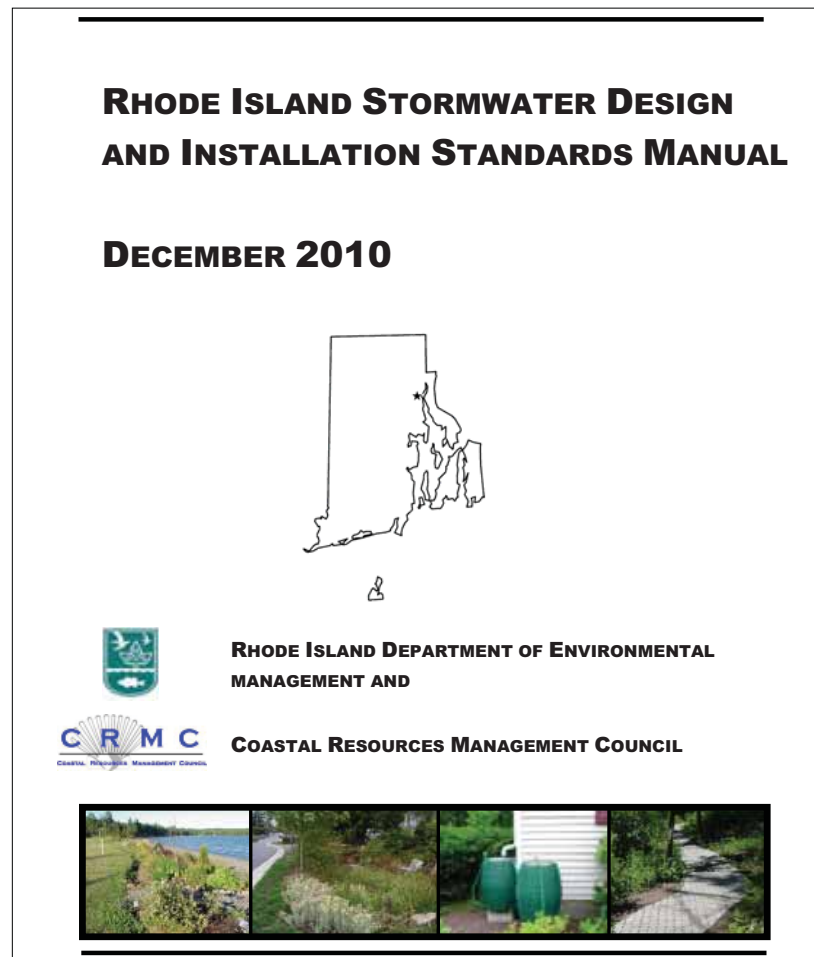
**Figure 1-3 Vegetated Swale Designed to Treat Stormwater Runoff.**



*(HW photo)*

Any remaining impacts that are unavoidable are primarily managed through the design of engineered stormwater treatment systems, for which the RI Stormwater Manual contains very specific design criteria.

**Figure 1-4 Rhode Island Stormwater Design and Installation Standards Manual.**



(<http://www.dem.ri.gov/pubs/regs/regs/water/swmanual.pdf>)

Avoiding and reducing impacts to natural hydrology through careful site planning and design is a very important component of the LID process, which can help to minimize the need for structural stormwater management practices. The extent to which avoidance and reduction of impacts can be achieved on a particular project is often determined by local regulations. Local development regulations and ordinances have the potential to facilitate or hinder the implementation of LID site planning and design strategies.

The chapters that follow in this guide will examine many of the common local regulatory topics and how they can be revised to accommodate LID, as well as reduce municipal service costs, prevent flooding, and preserve community character. The local regulatory tools and programs targeted in this guide for avoiding and reducing impacts are:

- Conservation Development;
- Resource Buffer Standards;
- Site Clearing and Grading Standards;
- Roadway Standards;
- Parking Requirements;
- Compact Development;
- LID Landscaping; and
- Special Purpose Ordinances.

The majority of these chapters are structured to first discuss the conventional approaches to these techniques and the common problems that occur in land use regulations today. These introductory sections are then followed by strategies that can be used to provide more innovative options to development and, where possible, examples of concrete standards that can be considered for zoning ordinances or land development regulations. Case studies and references have also been provided where examples can serve as models or provide specific insights to Rhode Island communities.

## 2.0 CONSERVATION DEVELOPMENT

### Current Practice

For years, Rhode Island communities have relied on conventional zoning and subdivision regulations to guide new growth. Rural and suburban towns adopted what officials perceived to be “large lot” zoning in an attempt to protect natural resources, community character and limit density. However, there were unintended consequences of this development pattern, also known as sprawl, that accelerated the loss of open space, resulted in negative impacts to natural resources, irreversibly altered the character of communities, and increased stormwater runoff volumes and pollution.<sup>1</sup> Although many towns adopted provisions for cluster development in the late 1980s, which was intended to concentrate density in one portion of the site in exchange for preserving open space elsewhere, there was no objective site analysis performed to determine what open space or natural resources were most important to protect in order to maintain or avoid impacts to pre-development hydrology.<sup>2</sup> Additionally, while cluster development can result in establishing protected open space, the wide variability in how development yield is established and the amount of open space provided has resulted in less than desirable results in protecting significant open space.

**Figure 2-1 Example of a Conventional Subdivision.**



*Conventional subdivisions carve up the landscape into cookie-cutter house lots that negatively impact pre-existing hydrology and community character. (<http://www.bing.com/maps/>)*

### Recommended Practice

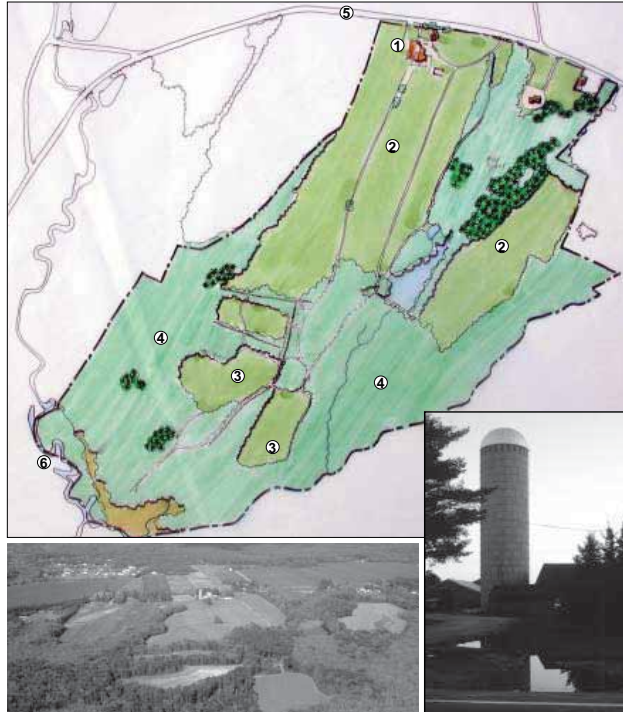
Conservation Development is a creative site design technique that allows a community to work collaboratively with developers to accommodate growth while avoiding impacts to natural resources and community character. Its compact form also preserves at least 50% of a given development site as open space, dependent upon the community’s open space desires.

<sup>1</sup> For a more in depth discussion of sprawl, see the Rhode Island Statewide Planning Program’s State Land Use Policies and Plan, *Land Use 2025*.

<sup>2</sup> An analysis of towns which did adopt cluster development is within the Rhode Island Statewide Planning Program’s *Technical Paper 148*.



**Figure 2-2 The Conservation Development Process.**



*The Kenyon Farm in South Kingstown is used as a case study in the Conservation Development Process. Resources on the site that were protected include active farmland, sensitive wetlands and wildlife habitat, and historic cultural features. After mapping these development constraints, alternatives were designed that prevent impacts to the resource areas. A priority development plan was then selected. Streets, trails and other infrastructure were designed, and a program for the open space areas developed. Finally, lot lines are drawn and ownership and maintenance of open space is established. (RI DEM, 2003)*

The way Conservation Development has been implemented by many Rhode Island communities follows the basic tenets of “designing with nature” as they were first introduced in the writings of Ian McHarg and became more explicit with works from Randall Arendt et al. (McHarg, 1995; Arendt et al., 1994). What separates Conservation Development from conventional and cluster subdivisions is the more thoughtful design process that uses existing opportunities and constraints to shape the final design. On a given parcel of land, objective site analysis is used to determine where development is most suitable, and conversely where development must be avoided to preserve sensitive natural resources. Resources identified and considered for preservation should include, but are not limited to, wetlands, hydric or prime agricultural soils, surface waters, steep slopes, areas subject to storm flow, vernal pools and associated naturally vegetated buffers. Conservation Development provides the flexibility necessary to locate the development envelope where it is most appropriate and makes it easier to maintain pre-development hydrology in the remainder of the site. The Rhode Island Conservation Development Manual identifies a ten step process for Conservation Development design (RI DEM, 2003):

1. Analyze the site;
2. Evaluate Site Context;
3. Designate Potential Conservation Areas;
4. Determine the Maximum Number of Units;
5. Locate Development Areas and Explore Alternatives;
6. Locate House Sites;
7. Lay Out Streets, Trails and Other Infrastructure;
8. Design and Program Open Space;
9. Draw in Lot Lines; and
10. Establish Ownership and Maintenance of Open Space.



In 2010, ten towns in RI adopted Conservation Development and 13 more towns have either drafted an ordinance or initiated the process.<sup>3</sup> All applicable rural and suburban communities should adopt Conservation Development to avoid impacts from new growth on local water quality and natural resources as well as to help maintain their community character.

## Perceptions and Realities

Despite the many benefits of Conservation Development, there are misconceptions that have limited its use (Table 2-1). Some developers are reluctant to use Conservation Development due to the perception that smaller lot sizes are less marketable. Some communities have not adopted Conservation Development since they feel smaller lots do not blend into their rural character. Others are concerned that smaller lots will yield less tax revenue than conventional larger lots.

**Table 2-1 Perceived Impediments to Conservation Development. (Adapted from CWP, 1998a)**

Perception	Facts, Case Studies, and Challenges
Smaller lot sizes and compact development are perceived as less marketable.	<p><b>Fact:</b> Many studies, including one from Rhode Island, show that conservation designs are highly desirable and have economic advantages including cost savings and higher market appreciation (Mohammed, 2006).</p> <p><b>Fact:</b> A survey of recent home buyers conducted by American Lives, Inc. noted that 77% of the respondents rated natural open space as extremely important (Fletcher, 1997).</p>
Community association management of conservation areas can be unreliable.	<p><b>Fact:</b> There are several options for maintaining conservation areas which can be reliable when properly implemented, such as non-profit organizations, municipal, or home owner association ownership.<sup>4</sup></p> <p><b>Fact:</b> Natural open space reduces maintenance costs and can help keep community association fees down (Arendt et al., 1994).</p>

<sup>3</sup> Rhode Island towns that have adopted Conservation Development at the time this guide was drafted include: Bristol, Burrillville, Cumberland, Exeter, Glocester, Middletown, North Kingstown, North Smithfield, Richmond, Smithfield, South Kingstown, and West Greenwich.

<sup>4</sup> See the Rhode Island Conservation Easement Guidance Manual (RI DEM, 2009).

<p>Conservation Developments are perceived as applicable only for upper income housing.</p>	<p><b>Fact:</b> There are many examples of moderate and lower income Conservation Developments in RI, such as Sandy Woods Farm in Tiverton and Woodbridge Estates in Woonsocket.</p>
<p>Conservation Developments are perceived as incompatible with adjacent land uses and are often equated with increased noise and traffic.</p>	<p><b>Fact:</b> Conservation design allows preservation of natural areas, using less space for streets, sidewalks, parking lots, and driveways (BASMAA, 1997).  <b>Fact:</b> A good design utilizing buffers can help alleviate incompatibility with adjacent land uses and still maintain the character of the area (NEIPC, 1997).  <b>Fact:</b> Sound level is measured as a function of vehicle speed (AASHTO, 1994). Conservation designs include narrower streets and other traffic calming features which decrease the speed of cars (FHA, 1996), and consequently, the level of sound.  <b>Fact:</b> If the number of residential units built is kept the same as the non-conservation designs, traffic impacts on the surrounding area should be similar.</p>
<p>Conservation Developments are perceived to yield less property tax.</p>	<p><b>Fact:</b> Conservation Development house lots yield as much if not greater tax returns than conventional lots (Millar, 2010).</p>

## Benefits

### Stormwater Benefits

It has been documented that Conservation Development can significantly reduce impervious surfaces, runoff volume, pollutant loadings, site disturbance, soil erosion, and development costs when compared to conventional development (Table 2-2, Table 2-3).

**Table 2-2 Redesign Analyses Comparing Impervious Cover and Stormwater Runoff from Conventional and Conservation Subdivisions. (CWP, 1998a)**

Residential Subdivision	Conventional Zoning for Subdivision	Impervious Cover at the Site			Percent Reduction in Stormwater Runoff
		Conventional Design	Open Space Design	Net Change	
Remlik Hall <sup>1</sup>	5 acre lots	5.4%	3.7%	-31%	20%
Duck Crossing <sup>2</sup>	3-5 acre lots	8.3%	5.4%	-35%	23%
Tharpe Knoll <sup>3</sup>	1 acre lots	13%	7%	-46%	44%
Chapel Run <sup>3</sup>	1/2 acre lots	29%	17%	-41%	31%
Pleasant Hill <sup>3</sup>	1/2 acre lots	26%	11%	-58%	54%
Prairie Crossing <sup>4</sup>	1/2 to 1/3 acre lots	20%	18%	-20%	66%
Rapahannock <sup>2</sup>	1/3 acre lots	27%	20%	-24%	25%
Buckingham Greene <sup>3</sup>	1/8 acre lots	23%	21%	-7%	8%
Belle-Hall <sup>5</sup>	High Density	35%	20%	-43%	31%

<sup>1</sup> Maurer, 1996; <sup>2</sup>CWP, 1998b; <sup>3</sup>DE DNREC, 1997; <sup>4</sup>Dreher, 1994; and <sup>5</sup>SCCCL, 1995.

**Table 2-3 Redesign Analysis Comparing Stormwater Pollution Loads from Conventional and Conservation Subdivisions. (CWP, 1998a)**

Residential Subdivision	Change in Phosphorous Load	Change in Nitrogen Load	Other
Remlik Hall <sup>1</sup>	-42%	-42%	
Prairie Crossing <sup>2</sup>	-81%	N/A	92% TSS reduction
Rapahannock <sup>3</sup>	-60%	-45%	
Belle-Hall <sup>4</sup>	-67%	-69%	

<sup>1</sup>Maurer, 1996; <sup>2</sup>CWP, 1998; <sup>3</sup>DE DNREC, 1997; <sup>4</sup>Dreher, 1994

Moreover, Conservation Development actually preserves meaningful open space and community character while accommodating growth. A key advantage to Conservation Development is that it allows for the establishment of new lot lines out of environmentally sensitive areas that should be protected to avoid the impacts to water quality such as surface waters, riparian buffers, wetlands, vernal pools and hydric soils. When lots comprise these sensitive areas, property owners have been known to inadvertently encroach upon and adversely impact these resources.

**Figure 2-3 Aerial Photograph of the Pawcatuck River.**



*The lush aquatic vegetation seen here is likely a result of phosphorous washing off the land where the buffer has been significantly encroached upon or completely removed. (RI DEM, 2000)*

## **Economic Benefits**

A Rhode Island study documented that Conservation Developments had a 40% reduction in construction costs, homes sold 47% faster and property values were 17% higher than comparable homes in a conventional development (Mohammed, 2006). Case studies from across the country have documented similar direct benefits (Arendt, 1999) and indirect economic benefits on a regional scale (Johnston, et al. 2006). For example, Johnston, et al. found that reduced downstream flooding as a result of conservation design generated between \$0 and \$7,800/acre in downstream property values for an area near Chicago, IL. Most of the direct cost savings are due to the reduction of roads and structural stormwater conveyance systems. The marketability of homes in a Conservation Development is also high since the homes are adjacent to permanently protected open space.

## **Case Studies**

There are several municipalities in Rhode Island today which employ innovative approaches to regulating residential design through conservation subdivision development. These municipalities have adopted standards that increase design flexibility and decrease impacts on the natural features near the site. Below are two examples of development projects that have displayed success with these innovative standards.

### **Sandy Woods Farm, Tiverton**

This residential development was permitted under Tiverton's regulations for Rural Residential Development. Still under construction as of March 2010, Sandy Woods Farms will have several innovative LID elements including:

- A compact residential development pattern that minimizes the length of roadway required (impervious cover) and the volume of stormwater runoff while minimizing

disturbance.

- Reduced reliance on stormwater detention ponds throughout the development in favor of increased small-scale on-site retention.
- Wind energy and solar energy utilized to supply electricity to the residential and commercial uses.
- One hundred and ten (110) acres of land (out of 174 total acres) permanently preserved as farmland, greenhouses, farm buildings, farm house and open space.
- Paved roadway width reduced from minimum required 22' width to 20' width to minimize impervious cover and stormwater runoff volume.

**Figure 2-4 Sandy Woods Farm Open Space and Farmland Plan.**



(Donald Powers Architects, Inc.)

Readers interested in looking more closely at this suite of strategies can review the ordinance through the Town's website: <http://www.tiverton.ri.gov/index.html>. The applicable text of the zoning ordinance is in Article IX.

### **Brown Farm, South Kingstown**

The 35-unit Brown Farm development displays an early model for conservation subdivision design. The developer utilized the design flexibility allowed under the Residential Cluster Development provisions within the Town's Subdivision and Land Development Regulations to consolidate the housing sites and preserve the open space. These regulations have since been replaced by the current provisions entitled *Flexible Design Residential Projects*; however, the initial regulations provided the essential elements of dimensional flexibility needed within Conservation Development. In particular, reductions to the lot area and frontage requirements allowed approximately 40% of the site to be dedicated as open space. Housing sites were placed within the historic frameworks of stone walls and were located to preserve

critical agricultural features. Key aspects of the development include:

- Development sited within existing sewer lines and a walkable distance from historic Town Center in South Kingstown.
- A central open space encircled by a roadway that serves as a natural stormwater drainage system.
- Siting of housing units, which protects critical natural features of the landscape, including agricultural uses and forested open space.
- Preservation of two historic homes and several stonewalls on the site.
- Architectural guidelines that preserve community character in context to the neighboring village.

Readers interested in looking more closely at the current regulations pertaining to *Flexible Design Residential Projects* can review the regulations through the Town's website: <http://www.southkingstownri.com/town-government/municipal-departments/planning>. The applicable text of the Subdivision and Land Development Regulations are in Article IV.A.

### **Burlingame Estates, Smithfield**

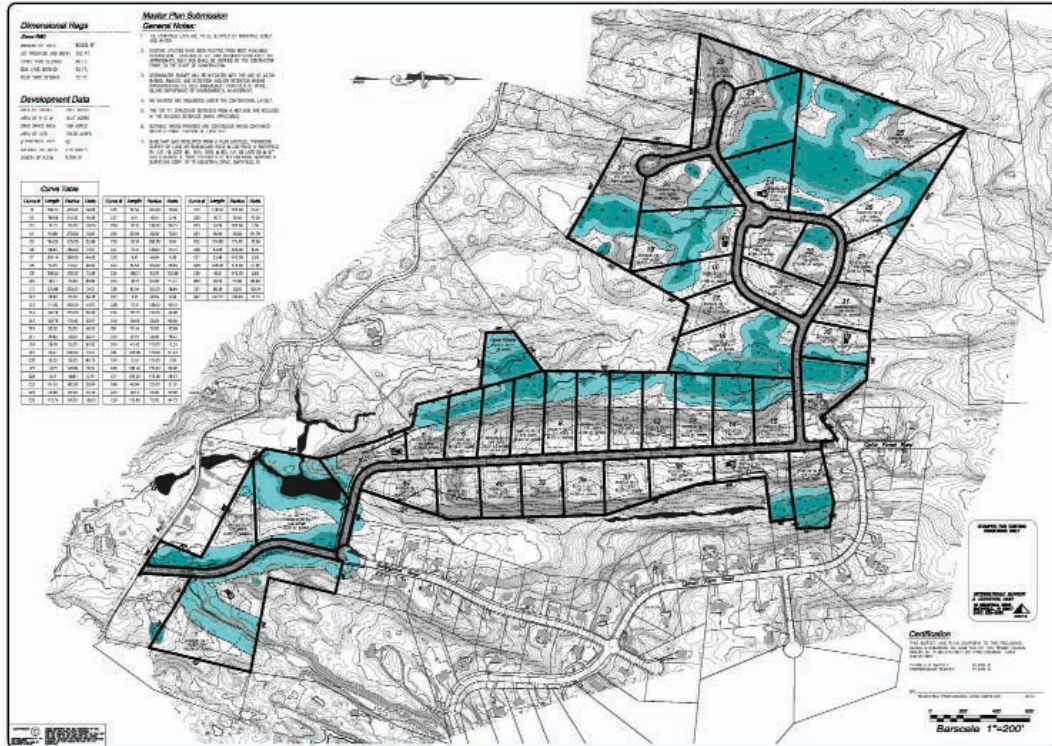
Smithfield adopted the ten step site planning and design process from the *RI Conservation Guidance Manual* to substantially improve a proposed 38 unit conventional large lot design. The conventional design was going to dramatically alter the pre-existing hydrology by carving up the entire parcel into 38 large lots with no protected open space. Moreover, lot lines were proposed for 24 house lots within the jurisdictional area of freshwater wetlands, along with new road construction adjacent to a stream.

The conservation design reduced the length of the road by 5,339 linear feet, avoided the stream corridor and kept the lot lines out of the wetlands, creating a safe buffer from development and sensitive resources. Instead of developing the entire site with three acre lots, half acre lots were created that permanently preserves 82% of the site as open space. This is an excellent example of how conservation development can effectively protect open space to maintain predevelopment hydrology, maximize the protection of surface waters and wetlands, reduce land clearing/grading, and minimize impervious cover. This site is undeveloped and the community land trust has negotiated to purchase some of the parcel.

For more information regarding the Town of Smithfield's Conservation Development Ordinance refer to Section 5.6 of Smithfield's Land Development and Subdivision Regulations, <http://www.smithfieldri.com/ordinances.htm>.

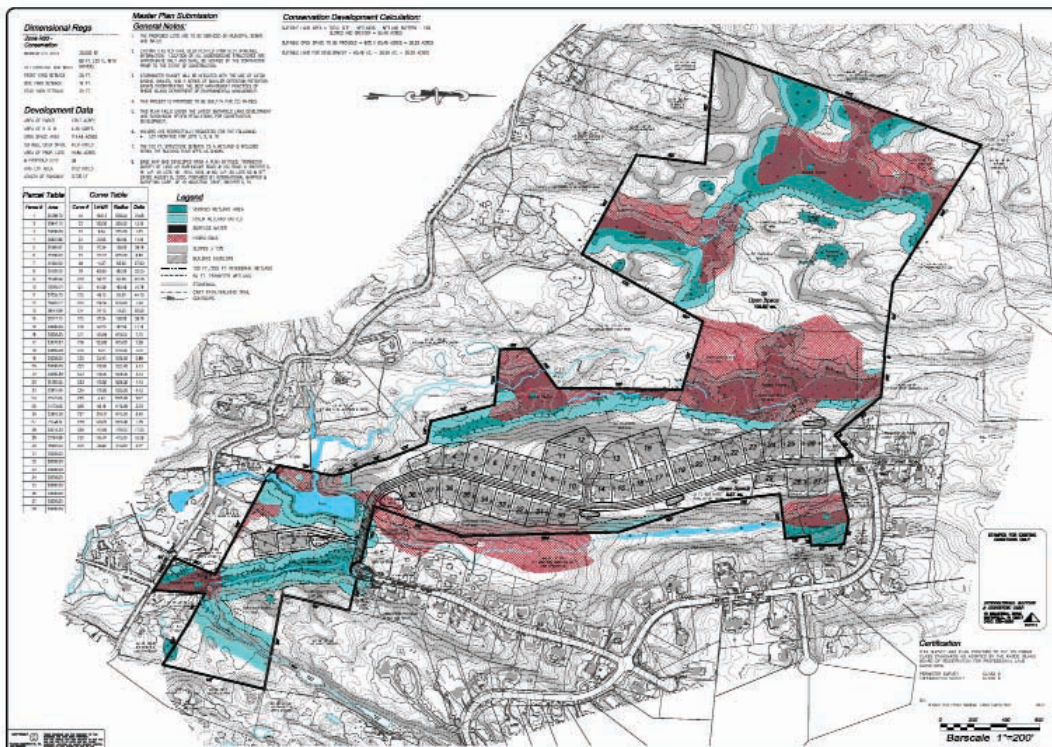


**Figure 2-5a Yield Plan.**



The conventional development dramatically alters pre-existing hydrology by converting the entire site into house lots, roads, and driveways. 24 lots encroached on wetlands and surface waters. (Town of Smithfield)

**Figure 2-5b Conservation Development Plan.**



The conservation development plan avoided the impacts by removing all lot lines from the 24 lots that would have impacted surface waters and wetlands. 82% of the site was preserved as open space. (Town of Smithfield)

## Suggested Resources

- American Association of State Highway Transportation Officials (AASHTO). 1994. *A Policy on Geometric Design of Highways and Streets*. Washington, D.C. No. 33. For purchase: <https://bookstore.transportation.org>.
- Arendt, Randall, E. Brabec, H. Dodson, C. Reid, and R. Yaro. December, 1994. *Rural by Design: Maintaining Small Town Character*. Planners Press, American Planning Association. 441 pp.
- Bay Area Stormwater Management Agencies Association (BASMAA). January 1997. *Start at the Source: Residential Site Planning and Design Guidance Manual for Stormwater Quality Protection*. 8 pp. [http://www.ccleanwater.org/Publications/StartAtTheSource/toc\\_testimonials\\_howtousebook.pdf](http://www.ccleanwater.org/Publications/StartAtTheSource/toc_testimonials_howtousebook.pdf).
- Center for Watershed Protection (CWP). 1998a. *Better Site Design: A Handbook for Changing Development Rules in Your Community*. Prepared for the Site Planning Roundtable. Elliot City, MD. 172 pp. For purchase/registration access: <http://www.cwp.org/>.
- Center for Watershed Protection (CWP). 1998b. *Nutrient Loading from Conventional and Innovative Site Development, for Chesapeake Research Consortium*. Elliot City, MD. For purchase/registration access: <http://www.cwp.org/>.
- Delaware Department of Natural Resources and Environmental Conservation (DE DNREC). 1997. *Conservation Design for Stormwater Management*. Dover, DE. 228 pp. [http://www.dnrec.state.de.us/dnrec2000/Divisions/Soil/Stormwater/New/Delaware\\_CD\\_Manual.pdf](http://www.dnrec.state.de.us/dnrec2000/Divisions/Soil/Stormwater/New/Delaware_CD_Manual.pdf).
- Dreher, D. and T. Price. 1994. *Reducing the Impact of Urban Runoff: The Advantages of Alternative Site Design Approaches*. Northeastern Illinois Planning Commission, Springfield, IL.
- Federal Highway Administration (FHA). 1996. *Pedestrian and Bicycle Crash Types of the Early 1990's*. U.S. Department of Transportation, Federal Highway Administration, Washington, D.C. FHWA-RD-95-163. <http://www.tfhr.gov/safety/pedbike/research/srd95163.htm>.
- Fletcher, June. 1997. *Home Buyers are Shunning Developers' Pricey Extras*. Wall Street Journal, Friday, November 21, 1997.
- Johnston, Douglas M. January/February 2006. *Downstream Economic Benefits of Conservation Development*. Journal of Water Resources Planning and Management, Vol. 132, No. 1, pp. 35-43, (doi 10.1061/(ASCE)0733-9496(2006)132:1(35)) Abstract: <http://scitation.aip.org/getabs/servlet/GetabsServlet?prog=normal&id=JWRMD5000132000001000035000001&dtype=cvips&gifs=yes&ref=no>.
- Maurer, George. 1996. *A Better Way to Grow: For More Livable Communities and a Healthier Chesapeake Bay*. Chesapeake Bay Foundation, Annapolis, MD.
- McHarg, Ian. 1995. *Design with Nature*. John Wiley & Sons. 208 pp.
- Millar, Scott. June, 2010. Personal communication.



- Mohammed, Raymond. 2006. *The Economics of Conservation Subdivisions: Price Premiums, Improvement Costs and Absorption Rates*. Urban Affairs Review. Vol. 41 (3): 376-399.
- Northeastern Illinois Planning Commission (NEIPC). 1997. *Reducing the Impacts of Urban Runoff: The Advantages of Alternative Site Design Approaches*. Chicago, IL. For purchase: <http://www.nipc.org/pubs-services/>
- Rhode Island Department of Environmental Management (RI DEM). 2000. (Rev. 2004). *Rhode Island Rural Design Manual*.
- Rhode Island Department of Environmental Management (RI DEM). 2003. *Rhode Island Conservation Development Guidance Manual*. 96 pp. <http://www.dem.ri.gov/programs/bpoladm/suswshed/pdfs/condev.pdf>.
- Rhode Island Department of Environmental Management (RI DEM). 2006. *Conservation Development Frequently Asked Questions*. 2 pp. <http://www.middletownri.com/documents/planning/Conservation%20Dev.%20FAQs.pdf>.
- Rhode Island Department of Environmental Management (RI DEM). 2008. *Rhode Island Conservation Design DVD*.
- Rhode Island Department of Environmental Management (RI DEM) and Narragansett Bay National Estuarine Research Reserve (NBNERR). 2009. *Rhode Island Conservation Easement Guidance Manual*. 27 pp. [http://www.nbwctp.org/CEG\\_Manual/RI%20Conservation%20Easement%20Guidance%20Manual.pdf](http://www.nbwctp.org/CEG_Manual/RI%20Conservation%20Easement%20Guidance%20Manual.pdf).
- South Carolina Coastal Conservation League (SCCCL). 1995. *Getting a Rein on Runoff: How Sprawl and Traditional Town Compare*, in SCCCL Land Development Bulletin (Number 7). Charleston, SC.

## 3.0 RIPARIAN BUFFER STANDARDS

### Current Practice

A riparian buffer is the area of land along streams and rivers and other open water bodies. Riparian buffers are essential to the ecology of aquatic systems. Riparian buffer zones, due to their location between surface waters and adjacent land areas, provide a range of important functions such as:

- Trapping/removing sediment and phosphorus, nitrogen, and other nutrients from runoff, as these pollutants lead to eutrophication of aquatic ecosystems;
- Trapping/removing other contaminants, such as pesticides;
- Providing habitat and contiguous travel corridors for wildlife;
- Stabilizing stream banks and reducing channel erosion;
- Storing flood waters, thereby decreasing damage to property;
- Maintaining habitat for fish and other aquatic organisms by moderating water temperatures and providing woody debris;
- Improving the aesthetics of stream corridors (which can increase property values); and
- Offering recreational and educational opportunities.

Because they maintain all of these services, riparian buffers can be thought of as a **“conservation bargain.”** Preserving a relatively narrow strip of land along streams and rivers, which is frequently unsuitable for other uses, can help maintain good water quality, provide habitat for wildlife, protect people and buildings from flood waters, and extend the life of reservoirs. The preservation and restoration of natural riparian buffers is considered to be the single most important management practice to protect water resources.

**Figure 3-1 Healthy Riparian Buffers.**



*The Clean Water Act goal that all waters should be fishable and swimmable is not achievable in Rhode Island's waters without the careful protection of riparian buffers (RI Rivers Council 2005 Establishment of Riparian and Shoreline Buffers: A Report to the Governor). ((c) 2008 Paul Somers, <http://bioimages.vanderbilt.edu/>)*

In Rhode Island, most freshwater wetlands, and the buffer areas protecting them, are regulated by the Freshwater Wetlands Act<sup>1</sup>, administered by the RI DEM. In addition, the RI CRMC regulates both fresh and tidal water resources and their buffers within the coastal zone of Rhode Island. The RI DEM Wetlands Program framework does not protect riparian buffers around all wetlands.<sup>2</sup> Both programs protect the minimum buffers as defined by the Act. Some weaknesses in the current regulatory program are as follows:

- RI DEM is not able to protect riparian buffers around all wetland systems. Special aquatic sites (vernal pools), small ponds less than one-quarter acre in size, and small forested/shrub wetlands less than three acres in size do not have regulated buffer zones;
- Authors of the Wetland Act had the foresight to protect adjacent buffer areas for other wetlands; however, the science regarding the importance of buffers has grown in the last 30 years, and we now know that current buffer zones regulated by law are often not large enough (e.g., the buffer zone width should consider sensitivity of wetland type and the land use that is proposed in both urban and suburban settings, as well as other factors); and
- State regulatory programs can be limited where substandard lots of record have been created and property use is grandfathered.

Most communities rely on RI DEM or RI CRMC to regulate buffers instead of exercising their zoning authority to help guide new development away from these sensitive areas. Eighteen RI municipalities have their own setbacks from wetland edges. Of these, seven communities regulate all disturbances within the setback; three communities regulate all buildings, structures and on-site wastewater treatment systems (OWTS), and the remaining eight regulate only OWTS location. In most cases the setbacks apply community-wide. A few communities either apply the setback only within a critical resource area or establish more stringent setbacks and/or performance standards for the critical area. R.I. General Law 45-24-30, the RI Zoning Enabling Act, enables communities to regulate development through a municipal zoning ordinance, giving them the ability to protect environmental resources while providing for orderly growth and development which recognizes:

- 3(ii) The natural characteristics of the land, including its suitability for use based on soil characteristics, topography, and susceptibility to surface or groundwater pollution.*
- 3(iii) The values and dynamic nature of coastal and freshwater ponds, the shoreline and freshwater and coastal wetlands.*

## Objective

Communities should use their land use regulatory power to require the preservation or restoration of a naturally vegetated buffer along all jurisdictional wetland resources to the maximum extent practicable<sup>3</sup> in both new development and redevelopment. The

<sup>1</sup> Rhode Island General Law 2-1-18 et seq.

<sup>2</sup> Refer to Perimeter Riverbank and Floodplain Wetlands Fact Sheet No.9 (RI DEM, 2007)

<sup>3</sup> For all references to “maximum extent practicable” in this guide, an applicant must demonstrate the following: (1) all reasonable efforts have been made to meet the standard in accordance with current local, State, and Federal regulations, (2) a complete evaluation of all possible management measures has been performed, and (3) if full compliance cannot be achieved, the highest practicable level of management is being implemented.

determination of buffer widths may require extra consideration in different locations depending on site specific characteristics, such as the presence of hydric soils and steep slopes.

**Figure 3-2 Example of Vegetated Riparian Buffers.**



*The green area in the figure represents the vegetated riparian buffer and the shaded blue area indicates a buffer zone of 100 feet on either side of the stream. (HW graphic)*

## Recommended Practice

A community buffer program should be created to establish a naturally vegetated buffer system along all streams and wetlands to supplement and expand upon the minimum requirements of the RI DEM and RI CRMC programs where applicable. Other important environmental features important to water quality preservation and enhancement should be included within the buffer, such as the 100-year floodplain and steep slopes. Communities implementing buffer programs should consider issues such as minimum width, target vegetation, allowable uses, and performance standards to avoid and minimize impact, as discussed below.

### Minimum Buffer Width

The effectiveness of various buffer widths has received much attention from the scientific and regulatory community, particularly in relation to water quality and local land use policy. A summary of over 150 scientific studies of effective buffer widths for a variety of biological, hydrologic, and physical functions is summarized by the Environmental Law Institute (2003). The Army Corps of Engineers (Corps) released national recommendations for riparian buffer design in 2000 (Fischer and Fischneich, 2000). Desbonnet, et al. (1994) published material specific to Rhode Island that can also be used to shed light on site specific buffer issues. Table 3-1 summarizes a wide range of buffer widths reported by these studies and provides a recommended minimum width to support a variety of buffer functions. A minimum buffer of 100 feet seems to be the most widely recommended width for protection of most buffer functions. Critical resources, such as public drinking water supplies may have larger



buffer requirements for enhanced protection and should be clearly identified in the buffer regulations. The values recommended represent the distance from the edge of a resource (e.g., stream bank, not the centerline).

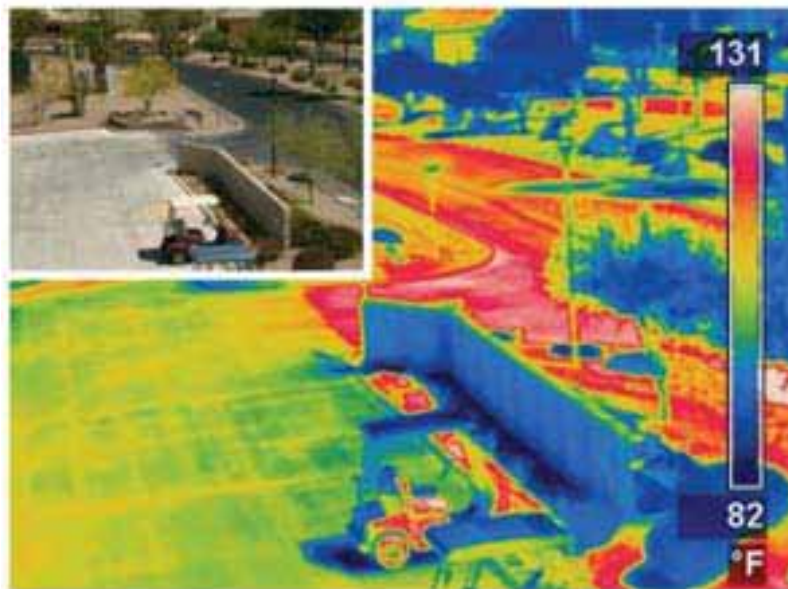
**Table 3-1 Recommended Minimum Buffer Widths. (Adapted from Environmental Law Institute, 2003)**

Function	Range of Riparian Buffer Widths		Minimum Recommended Buffer Width
	<i>Environmental Law Institute (2003)</i>	<i>Fischer and Fischneich (2000)</i>	
<b>Stream Stabilization</b>	30-170 ft	30-65 ft	50 ft <sup>1</sup>
<b>Water Quality Protection</b>	15-300 ft (remove nutrients) <sup>2</sup> 10-400 ft (remove sediment)	15-100 ft	100 ft <sup>3</sup>
<b>Flood Attenuation</b>	65-500 ft	65-500 ft	FEMA 100-year floodplain plus an additional 25 ft <sup>4</sup>
<b>Riparian/Wildlife Habitat</b>	10 ft-1 mile	100 ft-0.3 mile	300 ft <sup>5</sup>
<b>Protection of Cold Water Fisheries</b>	>100 ft (5 studies) 50-200 ft (1 study)	--	150 ft <sup>6</sup>

1. Larger buffers may be necessary based on steep slopes and highly erodible soils.
2. Different buffer designs should be considered for protection of different resources (coastal vs. inland).
3. Larger buffers may be necessary based on land use, resource goals, slope, and soils.
4. Additional buffer recommended to compensate for variability in flood model results at a site level and due to a changing climate.
5. Larger buffers may be necessary based on species and vegetation.
6. Larger buffers are necessary as the impervious cover in the watershed exceeds 8%.

In developed areas, as stormwater runoff flows over impervious surfaces such as asphalt and concrete, it increases in temperature before reaching a stream or other water body. Water temperatures are also increased due to shallow ponds and impoundments along a watercourse as well as fewer trees along streams to shade the water. Since warm water can hold less dissolved oxygen than cold water, this “thermal pollution” further reduces oxygen levels in suburban and urban streams. As described in the RI Stormwater Manual, temperature changes can severely disrupt certain aquatic species, such as trout and stoneflies, which can survive only within a narrow temperature range.

**Figure 3-3 Thermal Imaging of Pavement.**



*This infrared imagery shows how hot the surface of impervious cover can get, creating a situation where any subsequent stormwater runoff will have dramatic temperature impacts on adjacent streams. (Kaloush, Kamil; Pavements and the Urban Heat Island Effect)*

For the specific protection of trout habitat, a number of researchers have demonstrated that a larger protective buffer is needed. A 150-foot minimum “no touch” buffer zone seems to be the most widely recognized width for protection of cold water streams. Effective riparian buffer widths reported for protecting trout stream habitat range from 50 to 200 feet. Meyer et al. (2005) studied the correlation between forested buffers, in-stream temperature, and benthic substrate conditions in over 8,000 trout streams to evaluate the impact of a State policy to reduce required buffer widths from 100 to 50 feet. They found that the reduction of forested riparian buffers widths from 100 to 50 feet resulted in a 3-4 degree increase in stream temperatures and 11% increase in sediment in riffle habitats. While this change seems insignificant, this shift is expected to reduce the young trout populations by 81-88%.

### **Vegetative Target**

The ultimate target for the vegetation in the buffer should be specified. In general, this target should reflect the predevelopment, natural vegetative community present in the area. The target can be met by either preserving the existing vegetation or managing a disturbed buffer. To preserve existing buffers, these areas should be well marked on site plans, as well as in the field during construction. Disturbed areas should be either planted with native species or allowed to revert to the natural vegetation over time, with an aggressive invasive species management plan. Some selective clearing may be allowed in the outer portion of a buffer; in particular, to allow owners to remove dead or diseased trees that endanger personal property.

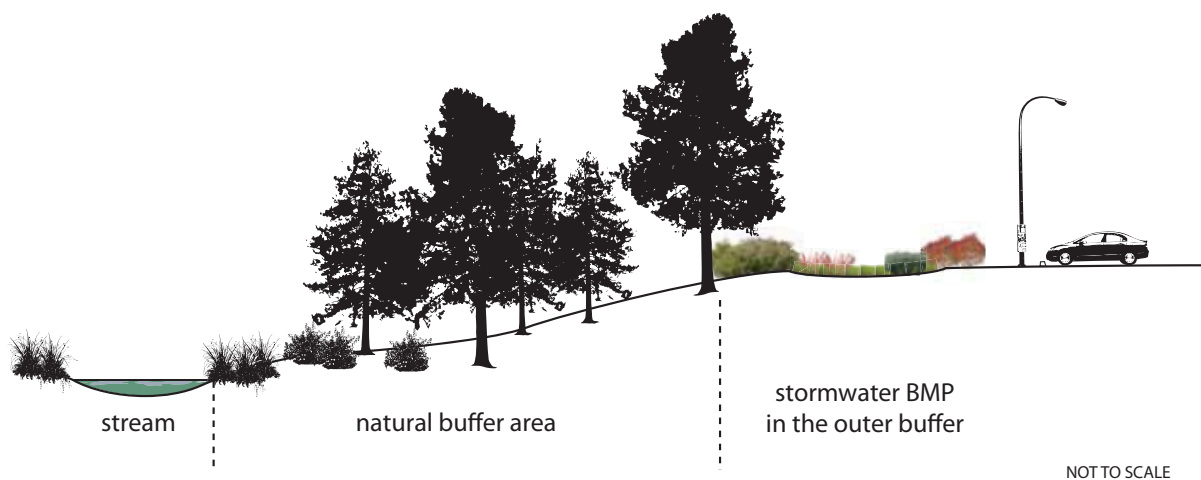
### **Buffer Uses**

While the ultimate goal of a community buffer program is to create a continuous vegetated area adjacent to resources, certain uses can be allowed. Buffer crossings (by utilities, roadways or pedestrian bridges) will be necessary in certain areas, and a buffer program should specify performance criteria that address items such as crossing width, angle, frequency, and

elevation. The allowable crossing width should be the minimum required for maintenance. Direct right angles are preferred since they require the least amount of clearing in the buffer. Only one road crossing per project should be allowed, and all utility crossings should be at least three feet below the streambed to prevent exposure by future channel erosion. The road crossing should be designed to pass the flow from the 100-year flood event. Bridges should be used for the crossing to the maximum extent practicable and if culverts are unavoidable, arch or box culverts should be used to minimize impact on wildlife. Communities must understand that all crossings are subject to RI DEM/CRMC review. For more information regarding techniques to avoid and minimize impacts to riparian buffers and wetlands refer to the *Wetland BMP Manual: Techniques for Avoidance and Minimization* (RI DEM, 2010).

Another potentially acceptable use within the buffer is for stormwater treatment; however, it is important to note that small scale LID practices located upgradient of buffer areas are preferable. Stormwater Best Management Practices (BMPs) should not be used in buffers where they significantly compromise the buffer's existing functions, and should only be used when no practical alternative exists. The outer portion of buffers can be utilized for stormwater management facilities, as long as sites are chosen carefully, located outside of State jurisdictional areas, and clearing of vegetation is minimized. One potentially effective way to use the edge of the buffer areas is to disperse channelized stormwater flow, which can be accomplished with small amounts of grading. Stormwater facilities should be designed with LID techniques and use the natural topography and undulating features that incorporate existing trees. See the RI Stormwater Manual for more information on how to properly design stormwater treatment practices.

**Figure 3-4 Example of Stormwater BMP in the Outer Buffer Zone.**



(HW graphic)

The red triangles in the graphic below represent the location of stormwater BMPs. Some of these have been effectively implemented in the very outer edge of the vegetated buffer (green area) along the riparian corridor in Montgomery County, MD. The shaded blue area indicates a buffer zone of 100 feet on either side of the stream as a reference.

**Figure 3-5 Locations of Stormwater BMPs Relative to Stream Buffers.**



*The red triangles represent stormwater BMPs; the green area represents the vegetated riparian buffer; and the shaded blue area indicates a buffer zone of 100 feet on either side of the stream as a reference. (HW graphic)*

## **Development Standards**

When discussing development criteria for buffer zones in the context of the urban environment, it is important to understand many of the site limitations that could exist by virtue of an existing development. Industrial structures that were developed many decades ago were constructed as close as possible to adjacent waters in order to take advantage of hydraulic power opportunities and the ability to dispose of waste into rivers and streams. In these cases, existing structures may severely inhibit the ability to restore any vegetated buffer adjacent to surface waters.

Due to these potential constraints, it is important for local review agencies to approach redevelopment situations with a flexible mindset. Re-establishing buffers where there are severe site restrictions should be considered under the 'maximum extent practicable' approach. Where minimum buffer widths are in place, these values should be seen as guidance principles within the context of urban redevelopment and should not preclude the possibility of redevelopment if specific buffer standards cannot be attained. Moreover, communities should be very flexible with other local regulations that may force development into buffer areas. These local regulations include, but are not necessarily limited to, parking requirements and front yard setbacks.



**Figure 3-6 Typical Subdivision Design Impacting Wetlands.**



Uniform requirements for lot size and setbacks cause subdivisions like the one in this aerial photo to consume far more land than necessary. This subdivision has encroached into wetland and pond buffer areas causing visible signs of eutrophication as indicated by the light green algal bloom. (Google Maps)

### General Guidelines

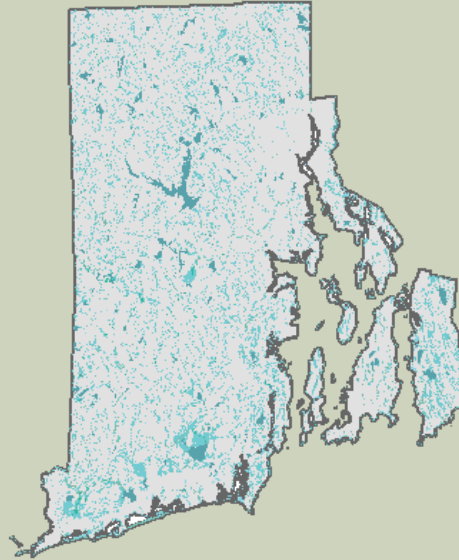
1. *Minimum Width:* See Table 3-1 for recommended minimum widths to achieve various buffer functions.

As mentioned above, this width represents an “ideal” condition that may not be achievable on all urban sites. However, the greatest buffer width that is practical should be maintained and restored and should not be reduced to less than 25 feet from wetland edge or below State regulatory requirements. **It should also be noted that both RI DEM and RI CRMC have regulatory jurisdiction for fresh water and coastal wetlands and surface waters including buffer requirements that may be greater than 100 feet. Local buffer programs should augment existing requirements.**

2. *Buffer Delineation and Mapping:* Preliminary mapping of surface water buffers can be performed through the use of readily available data from Rhode Island Geographic Information Systems (RIGIS, [www.edc.uri.edu/rigis/](http://www.edc.uri.edu/rigis/)). Although the accuracy of these features from RIGIS is not adequate for site-specific design, it can be used as an indicator of the presence of hydrologic features and can be useful during a pre-application conference or other preliminary discussions with municipal officials. These delineations are appropriate for conceptual site designs. Site designs for master plan review or beyond should include mapping of buffer delineations performed by a qualified wetland scientist in conjunction with a registered surveyor and be field verified by RI DEM or RI CRMC. Communities may want to consider requiring a RI DEM verified wetland edge at the pre-application phase, depending on the extent of potential impacts and scale of the project. A verified wetland edge should be required for any variance or special use permit application.



**Figure 3-7 State of Rhode Island Wetland Coverage.**



*(Rhode Island Geographic Information System)*

3. *Protecting Buffers During Construction:* Although buffer areas can be set aside as “undisturbed” on site plans and development applications, it is important for local officials and developers to understand the construction process and what risks could be posed to on-site vegetated buffer zones. **See Chapter 4 for more information on site clearing and grading guidance.** To minimize risks during the construction phase, the following precautionary measures can be required as part of a construction plan:
  - Buffer zones and limits of disturbance should be required on every drawing within every set of construction plans including, but not limited to, clearing and grading plans and sediment control plans;
  - Buffer limits should be staked out in the field prior to any construction activity;
  - Limits of disturbance can be marked with orange construction fence barriers with accompanying signs to prevent storage of construction materials and intrusion of vehicles, or any work beyond the limit;
  - A pre-construction walk-through should be performed with the municipal official or representative responsible for construction inspections and the person who was responsible for delineating the resource areas; and
  - Third-party inspectors can be hired by the community, at the applicant’s expense as authorized within the Subdivision and Land Development Regulations, to conduct site visits during and after construction to insure construction activity does not impair surface waters, wetlands, or buffers. **Refer to third-party review fees guidance in Chapter 9.**
  
4. *Landscaping:* Landscaping on a site already containing an existing vegetated

buffer should use only plant and tree varieties specifically cited as native species in Sustainable Trees and Shrubs for Southern New England, prepared by the University of Rhode Island, University of Massachusetts, and the United States Department of Agriculture (1993), or in another credible scientific document that specifically lists any proposed planting (genus and species) as being indigenous to the region. Appendix B in the RI Stormwater Manual also provides guidance on native landscaping. **In addition, refer to Chapter 8 for guidance on how to implement landscaping requirements on the local level.**

5. *Prohibited Activities:* Activities which can be typically prohibited by a local ordinance in the buffer include: land disturbing activities that may result in erosion or sedimentation, structures, impervious surfaces, application of fertilizers, herbicides and pesticides (except as needed to restore a buffer), storage tanks for petroleum products, septic system tanks/ leach fields (where applicable) and, clear cutting of vegetation other than maintenance mowing. Different levels of restriction can be placed in different regions of a buffer depending on how wide and densely vegetated the buffer zone is. In general, the shoreline region should serve as a “no-touch” zone, though uses such as passive recreation, including limited access paths for walking and canoe launches, can be allowed. The second zone should be limited to passive management and consist of shrub land and trees. The third and final zone, farthest from the surface water resource, would consist primarily of wooded canopy and can be managed for heavier foot and bicycle traffic and may be acceptable for stormwater BMPs with a LID design.
6. *Public Access or Recreation:* In both urban and rural settings, river corridors provide good opportunities for trails, or where appropriate, canoe/kayak launch sites. No proposed development adjacent to a vegetated buffer should prevent existing and, where appropriate, new public access to the resource. Any proposed public access or recreation should be consistent with the Community Comprehensive Plan, the State Comprehensive Outdoor Recreation Plan (SCORP) State Guide Plan 152 (RI DEM, 2009), and applicable State regulations.
7. *Redevelopment Criteria:* Any proposed redevelopment of a site containing a buffer zone to an existing surface water or wetland resource should demonstrate that post-development conditions will improve the capacity of the buffer to: provide continued public access to the resource (assuming access exists); protect the resource area from stormwater runoff; and/or provide wildlife habitat. Improvement strategies can include, but would not be limited to:
  - Re-establish vegetation in areas of the buffer that were previously developed or impervious to the maximum extent practicable. A minimum of 25 feet beyond jurisdictional wetlands is recommended. This can be accomplished by requiring a mitigation planting ratio based on new impervious area proposed within an existing degraded buffer (e.g., 3:1).
  - Provide pre-treatment of stormwater runoff directed to the buffer zone, and design site runoff to enter the buffer as sheet flow. Where necessary, incorporate water quality BMPs into the buffer zone to treat concentrated inflow.

- Maintain historic public access points to surface water resources.
- Consolidate access points and restore the buffer zones in old access areas.
- Enhance the existing buffer vegetation with native vegetation and remove exotic and invasive species. Special care should be taken when removing invasive species to compensate for any loss of pollutant attenuation or habitat. Invasive species removal should be performed by a qualified professional<sup>4</sup> and only if a sustainable future condition with native species is assured.

**Figure 3-8 Buffer Zone Planting.**



Careful placement and installation of native vegetation is required for restoring buffer areas that were cleared. (HW photo)

8. *Buffer Flexibility:* Building flexibility into buffer zone guidelines allows developers to creatively address existing site constraints and, by providing developers with different options, avoids any claims that buffering criteria are too restrictive. Provisions for flexibility relative to buffer zone criteria can include one or more of the following:
  - *Preserving or Restoring Buffer Zones as Open Space:* The applicant may enter into negotiations with the municipality to dedicate a buffer area to the City or Town along with access rights across the property as a potential improvement to the buffer. This situation may be particularly attractive in areas where the resource already provides a significant level of recreational opportunity to the general public. Conservation easements are also an option that a landowner could use as a tax benefit by either donating the land to a land trust or to the community.
  - *Buffer Averaging:* Local criteria for buffer zones can use an averaging approach

<sup>4</sup> A qualified professional has the educational background and/or experience to properly identify and remove invasive species.

where the average width of the buffer across the site is either optimized or reaches the specific target.

- *Density Compensation:* If buffer restrictions render a significant amount of land as “undevelopable,” provisions in local zoning could allow for increased density on the remainder of the site to add value to the development provided that there is adequate infrastructure (water, sewer, and stormwater) to support the increase. An example of density credit calculations can be found in Article 39 of The Practice of Watershed Protection “The Architecture of Urban Stream Buffers” (Schueler et al., 2000).
- *Waivers or Deviations:* As a rule of thumb with any ordinance or land development regulations, language should provide the permitting authority the power to waive a portion of, or reduce a particular criterion where legally permitted by an enabling local ordinance.
- *Off-Site Buffer Restoration:* If the establishment of a buffer on an existing site is not possible, communities can consider requiring a developer to restore a buffer area off-site or place money for restoration in a restricted receipt account, referred to as “fee-in-lieu.” In any case the restoration should be in the same watershed. This requirement should be based on clearly stated public needs and policy goals outlined for the community buffer program within the Comprehensive Plan and clear standards would need to be specified in the subdivision and land development regulations.
- *Net-Improvement to the Site:* Examine the quality of existing stormwater discharge or other conditions such as hardened shorelines to find other areas that might be improved in lieu of enforcing stringent buffer width restrictions.

## Perceptions and Realities

Perception	Reality
Buffer standards will result in a loss of developable land.	A 100-foot wide stream buffer typically consumes only 5% of land in a watershed. In addition, flexibility can be incorporated into local regulations to protect property owners.
Landowners with buffers are required to provide public access.	Public access is not necessary for an effective buffer program; instead, they can be maintained in private ownership through deed restrictions and conservation easements.
Buffer programs will be a hardship on a community’s staff and resources.	In a survey by Heraty (1993), most government participants stated that their staff spent only 1 – 10% more time to administer a buffer program.

RI DEM and RI CRMC already protect all buffers.	RI DEM regulations are limited in some cases, and enforcement of buffers over time is challenging when lots are created adjacent to sensitive buffers.
---	--

**Successful Buffer Programs**

The key to a successful buffer program is education and flexibility. Buffers should be well demarcated by permanent boundaries and/or signage and also clearly noted on all deeds and recorded site plans and subdivision / land development plans. Buffer owners should be educated about their responsibilities and the benefits of buffers. Most encroachment issues are due to ignorance about the buffer program rather than complete disregard. In addition, flexible measures can be incorporated in a buffer program with many of the techniques described above (e.g., buffer averaging, conservation easements, and variances) and can go a long way toward gaining the support of the public.

**Figure 3-9 Wetland Buffer Signage.**



*(A. Kitchell)*

**Benefits**

Buffer zones to fresh and saltwater resources—whether they are rivers, streams, bays, ponds, or wetlands—play an integral role in both protecting these resources and providing habitat for wildlife. The use of local land use authority to preserve or restore vegetated buffers is critical to the overall health of watershed systems and to public health and safety. The following table is taken from the Center for Watershed Protection’s *The Practice of Watershed Protection* (Schueler et al., 2000) and clearly illustrates the myriad of benefits derived from proper buffer management and restoration. Specific benefits as related to stormwater and economics are listed below Table 3-2.



**Table 3-2: Twenty Benefits of Urban Stream Buffers**

*(f)* = Benefit Amplified by or Requires Forest Cover

- 1. Reduces watershed imperviousness by 5%.** An average buffer width of 100 feet protects up to 5% of watershed area from future development.
- 2. Distances areas of impervious cover from the stream.** More room is made available for placement of stormwater practices, and septic system performance is improved. *(f)*
- 3. Reduces small drainage problems and complaints.** When properties are located too close to a stream, residents are likely to experience and complain about backyard flooding, standing water, and bank erosion. A buffer greatly reduces complaints.
- 4. Stream “right of way” allows for lateral movement.** Most stream channels shift or widen over time; a buffer protects both the stream and nearby properties.
- 5. Effective flood control.** Other, expensive flood controls not necessary if buffer includes the 100-yr floodplain.
- 6. Protection from streambank erosion.** Tree roots consolidate the soils of floodplain and stream banks, reducing the potential for severe bank erosion. *(f)*
- 7. Increases property values.** Homebuyers perceive buffers as attractive amenities to the community. 90% of buffer administrators feel buffers have a neutral or positive impact on property values. *(f)*
- 8. Increased pollutant removal.** Buffers can provide effective pollutant removal for development located within 150 feet of the buffer boundary, when designed properly.
- 9. Foundation for present or future greenways.** Linear nature of the buffer provides for connected open space, allowing pedestrians and bikes to move more efficiently through a community. *(f)*
- 10. Provides food and habitat for wildlife.** Leaf litter is the base food source for many stream ecosystems; forests also provide woody debris that creates cover and habitat structure for aquatic insects and fish. *(f)*
- 11. Mitigates stream warming.** Shading by the forest canopy prevents further stream warming in urban watersheds. *(f)*
- 12. Protection of associated wetlands.** A wide stream buffer can include riverine and palustrine wetlands that are frequently found along the stream corridor.
- 13. Prevent disturbance to steep slopes.** Removing construction activity from these sensitive areas is the best way to prevent severe rates of soil erosion. *(f)*
- 14. Preserves important terrestrial habitat.** Riparian corridors are important transition zones, rich in species. A mile of stream buffer can provide 25-40 acres of habitat area. *(f)*
- 15. Corridors for conservation.** Unbroken stream buffers provide “highways” for migration of plant and animal populations. *(f)*
- 16. Essential habitat for amphibians.** Amphibians require both aquatic and terrestrial habitats and are dependent on riparian environments to complete their life cycle. *(f)*
- 17. Fewer barriers to fish migration.** Chances for migrating fish are improved when stream crossings are prevented or carefully planned.

**18. Discourages excessive storm drain enclosures/channel hardening.** Can protect headwater streams from extensive modification.

**19. Provides space for stormwater BMPs.** When properly placed, the outer zone of the buffer can be an acceptable location for stormwater practices that remove pollutants and control flows from urban areas.

**20. Allowance for future restoration.** Even a modest buffer provides space and access for future stream restoration, bank stabilization, or reforestation.

## Stormwater Benefits

Effective resource buffers minimize the need for flood control by helping to attenuate stormwater flows before they reach a water body and allowing the lateral movement of streams. By preventing development in the buffer area, the overall quantity of stormwater in the watershed is reduced, which will also help to reduce streambank erosion and flooding. Finally, vegetated buffers function as natural filtering mechanisms for removing sediment, nutrients, bacteria and other pollutants typically found in stormwater runoff.

Buffers can be very important for coldwater trout streams in particular, not only providing shade for the stream itself but also by helping to cool and infiltrate stormwater before it reaches the stream. They are also sources of large woody debris, which is very important for trout habitat. By infiltrating stormwater runoff, buffers increase groundwater recharge, which in turn helps to maintain the baseflow of the stream.

## Economic Benefits

Stream and wetland buffers can actually have economic benefits to communities in the long run. The presence of buffers improves the market value of adjacent properties. As listed in the Better Site Design Handbook (1998), examples of the positive market influence of buffers include:

- When managed as a “greenway,” stream buffers can increase the value of adjacent parcels as illustrated by several studies. Pennypack Park in Philadelphia is credited with a 33% increase to the value of nearby property. A net increase of more than \$3.3 million in real estate is attributed to the park (Chesapeake Bay Foundation, 1996).
- Nationally, buffers were thought to have a positive or neutral impact on adjacent property in 32 out of 39 communities surveyed (Schueler, 1995).
- Effective shoreline buffers can increase the value of urban lake property. A recent study in Maine found that increased water clarity (visibility depth increased by three feet) resulted in \$11 to \$200 more per foot of shoreline property, potentially generating millions of dollars in increased value per lake (Michael et al., 1996).

In addition, buffers help save municipalities money by reducing the need for floodwater storage and stormwater treatment. Drainage problems and thus complaints from the public are reduced by buffers, which saves municipal staff time and money. Examples of cost saving which may be realized due to buffer presence include:

- The Minnesota Department of Natural Resources (MN DNR) estimated cost savings of \$300 per acre-foot associated with a minimized need for floodwater storage due to the preservation of riparian wetlands;
- Forested stream and shoreline buffers situated on the flat soils of the coastal plain have been found to be effective in removing sediment, nutrients, and bacteria from stormwater runoff and septic system effluent in a wide variety of rural and agricultural settings along the East Coast (Desbonnet et al., 1994);
- Buffers can sharply reduce the number of drainage complaints received by municipal public works departments; and
- Buffers are often an effective means to mitigate or even prevent stream or shoreline erosion.

## Case Studies

Within Rhode Island, most communities rely on RI DEM or RI CRMC to regulate buffers to wetlands and surface waters instead of exercising local regulatory authority to help guide new development away from these resources. However, there are some communities that are applying unique strategies within the regulation of wetland, riparian or coastal areas to increase protective measures. There are a variety of approaches for regulating buffers such as: enforcement through zoning overlay districts, applying additional standards on certain uses through special use permits, or addressing the various impacts of wastewater within the buffer area. The standards from two Rhode Island communities, Barrington and South Kingstown, are reviewed here as two different approaches to wetlands protection in local ordinances.

### Barrington, Wetlands Overlay District

The Town of Barrington has adopted an overlay district within its zoning ordinance to provide additional protection to its wetland areas. The overlay is described as follows:

*The Wetlands Overlay District shall consist of coastal wetlands, defined as salt marshes bordering on tidal waters, and freshwater wetlands, defined as those areas of 1/2 acre or greater, that are inundated or saturated with surface and/or ground water at a frequency or duration sufficient to support, and under normal circumstances do support, a prevalence of vegetation typically adapted for life in saturated soil conditions. (Zoning Ordinance Section 185-171)*

The regulations within the overlay are triggered by new construction, reconstruction, or expansion of existing buildings, or new, expanded, or modified uses of property within 100 feet of the overlay district. One of the primary mechanisms used to protect wetland resources is the list of prohibited activities including:

- A. The discharge or introducing of any organic or inorganic chemical or biological pollutants.
- B. The storage of any hazardous, toxic or infectious materials or wastes.
- C. The placing or depositing of any solid waste or debris.
- D. The discharging of any effluent creating a thermal gradient deleterious to indigenous plants, fish or wildlife.

In addition to the prohibited activities, any activity that falls within 100 feet of the overlay district must meet several development standards to be eligible for a special use permit under the overlay regulations. These development standards are provided to minimize, to the degree possible, any negative impacts to the wetlands through the following provisions:

- A. All new structures and expansions, paved areas, and land disturbances will be set back at least 100 feet from the wetland edge.
- B. The proposed project will not obstruct floodways in any detrimental way, or reduce the net capacity of the site and adjoining properties to retain floodwaters.
- C. The proposed project will not cause any sedimentation of wetlands, and will include all necessary and appropriate erosion and sediment control measures.
- D. The proposed project will not reduce the capacity of any wetland to absorb pollutants.
- E. The proposed project will not directly or indirectly degrade the water quality in any wetland or water body.
- F. The proposed project will not reduce the capacity of any wetland to recharge groundwater.
- G. The proposed project will not degrade the value of any wetland as a spawning ground or nursery for fish and shellfish or habitat for wildlife or wildfowl.

These regulations provide an additional layer of protection above and beyond the jurisdiction of RI DEM and RI CRMC. The overlay district method is a very straightforward approach for local communities that have the capacity for a comprehensive wetlands mapping process to determine appropriate boundaries for the district.

Readers interested in looking more closely at this suite of strategies can review the ordinance through the Town's website: <http://www.ci.barrington.ri.us/>. The applicable text of the zoning ordinance begins in ARTICLE XXV, § 185-169 — § 185-179.

### **South Kingstown, Special Use Permits**

The Town of South Kingstown provides additional protection to wetlands through identifying uses that trigger a special use permit within the Town's zoning ordinance.<sup>5</sup> Several items have been identified for this additional permitting requirement, such as: individual sewage disposal systems (ISDS)<sup>6</sup>, hazardous waste management facilities, and accessory apartments. The regulations for such uses are as follows:

No ISDS shall be allowed within:

- 150 feet from a freshwater wetland
- 150 feet from a river
- 200 feet from a flowing body of water having a width of 10 feet or more
- 150 feet from a floodplain
- 150 feet from a coastal wetland

<sup>5</sup> It should be noted that the Town of South Kingstown was considering amendments to this ordinance at the time this manual was being drafted. No changes had been made before the manual was published, but readers may find that certain provisions have changed when compared to the case study presented here.

<sup>6</sup> Since the adoption of this ordinance, RI DEM has changed their official name for septic systems from Individual Sewage Disposal Systems (ISDS) to On-site Wastewater Treatment Systems (OWTS).

No hazardous waste management facility shall be allowed within 500 feet of areas identified as freshwater wetlands or areas in a special flood hazard district.

An accessory apartment which is not serviced by a public sewer system may be established by special use permit only, and the accessory apartment along with the associated ISDS must meet heightened standards relative to its location near wetland resources.

Readers interested in looking more closely at this suite of strategies can review the ordinance through the Town's website: <http://www.southkingstownri.com/town-government/municipal-departments/building-inspection-and-zoning>. The applicable text of the zoning ordinance begins in Section 504.



## Suggested Resources

- Chesapeake Bay Program (CBP), Nutrient Subcommittee, Forestry Workgroup. 1996. *Forest and Riparian Buffer Conservation: Local Case Studies from the Chesapeake Bay Program*. U.S. Department of Agriculture (USDA). 40 pp. [http://www.chesapeakebay.net/content/publications/cbp\\_12364.pdf](http://www.chesapeakebay.net/content/publications/cbp_12364.pdf).
- Desbonnet, A., P. Pogue, V. Lee and N. Wolf. 1994. *Vegetated Buffers in the Coastal Zone: A Summary Review and Bibliography*. Providence, RI: University of Rhode Island.
- Environmental Law Institute (ELI). 2003. *Conservation Thresholds for Land Use Planners*. Washington, D.C. For purchase: [www.elistore.org](http://www.elistore.org).
- Flinker, P., H. Dodson, R. Claytor, N. Kelly, S. la Cour, H. Blanchette, and K. Wilson. 2005. *Rhode Island Urban Environmental Design Manual*. Rhode Island Department of Environmental Management (RI DEM) – Sustainable Watersheds Office. Providence, RI.
- Heraty, M. 1993. *Riparian Buffer Programs: A Guide to Developing and Implementing a Riparian Buffer Program as an Urban Stormwater Best Management Practice*. Metropolitan Washington Council of Governments. USEPA Office of Oceans, Wetlands and Watersheds.
- Hornbach, W. 1993. *Private Property and Community Rights – What Communities Can Still Do After Development*. *Lucas* 3(1):14.
- Kaloush, Kamil. 2010, January 28. *Pavements and the Urban Heat Island Effect*. Presented at EPA's Cool Pavement Webcast. Downloadable from <http://www.epa.gov/heatisd/resources/pdf/2ScientificOverview-Pavements-HeatIslands-Kaloush-ASU.pdf>.
- Meyer, J., K. Jones, G. Poole, C. Jackson, J. Kundell, B. Rivenbark, E. Kramer, and W. Bumback. 2005. *Implications of Changes in Riparian Buffer Protection for Georgia's Trout Streams*. Downloadable from [www.rivercenter.uga.edu/publications.htm](http://www.rivercenter.uga.edu/publications.htm).
- National Research Council (NRC). 2008. *Urban Stormwater Management in the United States*. National Academy of Sciences, National Academies Press. 624 p.
- Rhode Island Department of Environmental Management (RI DEM). 2007. *Perimeter, Riverbank and Flood Plain Wetlands*. Wetlands Fact Sheet 9. <http://www.dem.ri.gov/programs/benviron/water/wetlands/pdfs/wfs09.pdf>.
- Rhode Island Department of Environmental Management (RI DEM). 2009. *Ocean State Outdoors: Rhode Island's Comprehensive Outdoor Comprehensive Plan, State Guide Plan Element 152*. 139 pp. <http://www.planning.ri.gov/landuse/scorp09.pdf>.
- Rhode Island Invasive Species Council. 2001. *Invasives: List*. Rhode Island Natural History Survey. Kingston, RI. <http://www.rinhs.org/ri-invasive-species-resources/invasive-list/>.
- Schueler, T.R. 2000. *The Architecture of Urban Stream Buffers*. The Practice of Watershed Protection, editors Thomas R. Schueler and Heather K. Holland, Center for Watershed Protection, Ellicott City, MD.

- Schueler, T. 1995. *Site Planning for Urban Stream Protection*. Center for Watershed Protection/ Metropolitan Washington Council of Governments. Silver Spring, MD. For purchase/ registration access: <http://www.cwp.org/>
- Schueler, T.R., L. Fraley-McNeal, K. Capiella. 2009. *Is Impervious Cover Still Important? Review of Recent Research*. Journal of Hydrologic Engineering. 14: 309-315.
- Stranko, Scott A., R. Hilderbrand, R. Morgan, M. Stanley, A. Becker, A. Roseberry-Lincoln, E. Perry, P. Jacobson. 2008. *Brook Trout Declines with Land Cover and Temperature Changes in Maryland*. North American Journal of Fisheries Management. American Fisheries Society 28: 1223-1232.
- Welsch, David J. 1991. *Riparian Forest Buffers - Function for Protection and Enhancement of Water Resources*. NA-PR-07-91. [Broomall, PA:] U.S. Department of Agriculture, Forest Service, Northern Area State & Private Forestry.
- Wenger, Seth. 1999 (revised). *A Review of the Scientific Literature on Riparian Buffer Width, Extent and Vegetation*. For the Office of Public Service & Outreach Institute of Ecology University of Georgia.

## 4.0 SITE CLEARING AND GRADING STANDARDS

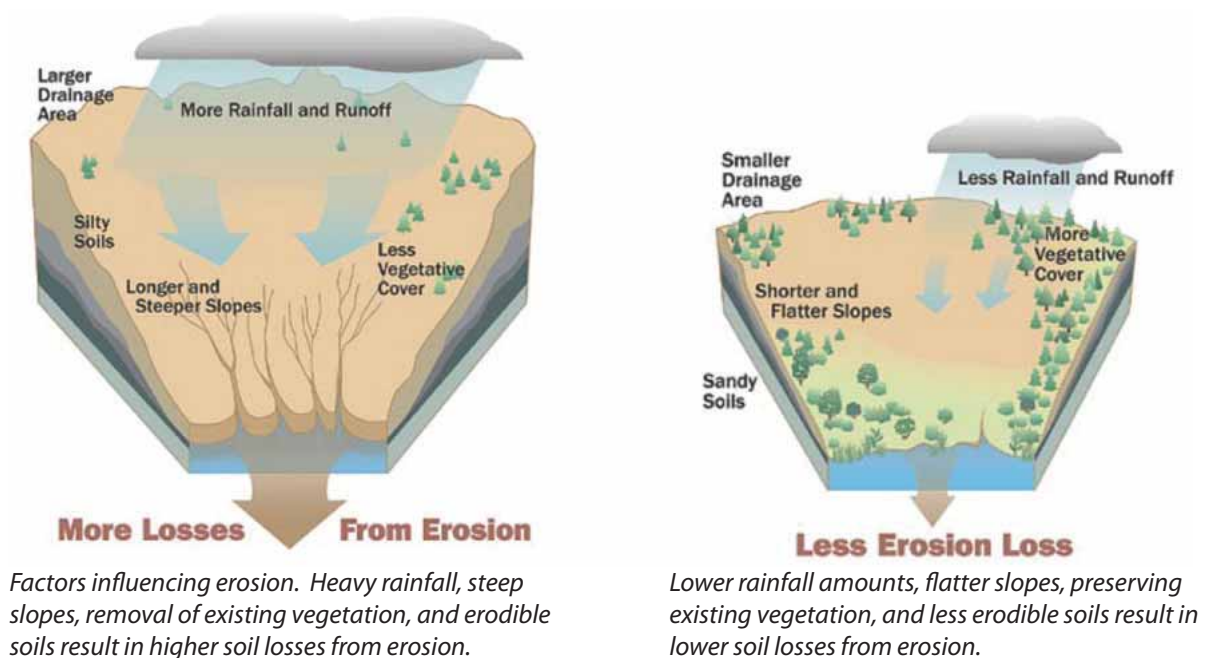
### Current Practice

Clearing vegetative cover and then grading a site are arguably the most destructive stages in the development process and can dramatically impact pre-existing hydrology. Soils are exposed to erosion, the site is compacted by heavy equipment, and the natural terrain and drainage are completely altered. While most RI towns do have some type of erosion and sediment control (ESC), and 21 municipalities have self-certified compliance with the Storm Water Phase II General Permit for Small Municipal Separate Storm Sewer Systems (Phase II MS4 permit) requirements for construction site stormwater management through local ordinances as of August 2010, often times clearing and grading issues are not adequately addressed or enforced at the local level. This chapter discusses how a community can revise those existing ordinances or adopt new versions that include standards to minimize site clearing and grading. The ordinances covered in this chapter include:

- Erosion and Sediment Control Ordinances;
- Grading Ordinances; and
- Forest Conservation or Tree Protection Ordinances.

In addition, ordinances that encourage conservation development are also important for minimizing clearing and grading. **Conservation development is a site design technique that is discussed in detail in Chapter 2.**

**Figure 4-1 Factors Affecting Erosion from a Construction Site.**



(Tetra Tech, Kentucky Erosion Prevention and Sediment Control Field Guide)

## Objective

Communities should modify or create ordinances and regulations that require applicants to maintain as much natural vegetation as possible and limit clearing, grading, and land disturbance activities to the minimum needed for construction, maintenance, and emergency services.

## Recommended Practice

### Erosion and Sediment Control Revisions

Many communities in Rhode Island have recognized the destructive consequences of erosion and sedimentation from construction sites and have adopted ESC standards in a separate ordinance or as a part of existing subdivision and land development regulations. However, most communities focus on erosion issues after they occur or are created. For example, many communities have ESC references in their regulations that require slope stabilization after clearing and grading. The ESC practices are viewed separately from the design process and, instead of minimizing clearing and grading, simply focus on collecting eroded sediment and keeping it on a development site. A much more effective approach is to prevent excessive clearing and grading from the beginning of a development project during the site design process. The following is a series of recommended standards that should be incorporated into ESC regulations or as a separate provision of a municipality's subdivision and land development regulations.

- Clearing and grading requirements should be applied to all land disturbance activities greater than 1,000 square feet, or the displacement of 50 cubic yards of soil or more, even when other permits are not necessary. This will help a community regulate and prevent the clearing of a parcel by a landowner who is only preparing to sell it to a developer and might not ordinarily need a permit from the municipality.
- Site footprinting should be employed at a development site. Site footprinting is a technique that reduces clearing to the minimum area required for building and roadway footprints, construction access, and safety setbacks. The United States Green Building Council (USGBC) Leadership in Energy and Environmental Design (LEED) Site Development credit for protecting or restoring habitat applies to sites that limit disturbance around structures to 40 feet and to 15 feet beyond the edge of a roadway (USGBC, 2006).
- Prior to the start of any land disturbance activities on a site, the developer should be required to physically mark limits of no land disturbance with tape, signs, or orange construction fence consistent with limits of disturbance shown on approved plans, so that regulators and workers can see the areas to be protected. At a minimum, the 100-year floodplain, wetlands and associated buffers, areas with erodible soils, tree stands and other natural open space to be protected, and areas designated for stormwater practices and on-site treatment systems, should be protected from disturbance and/or compaction. These limits should be reviewed

and modified as necessary during a mandatory on-site preconstruction meeting.

**Figure 4-2 Example of Buffer Zone Signage.**



*An effective way to delineate buffers to be protected from construction is with signs and temporary fencing. (HW photo)*

- In order to reduce the duration of soil exposure, land disturbance activities exceeding one acre in size (including lot development) should not be initiated without a sequencing plan that requires stormwater controls to be installed and the soil stabilized, as disturbance beyond the one acre continues. A construction phasing plan should be submitted and approved by the local planning board as part of the subdivision review process. Mass clearing and grading of the entire site should not be permitted. In addition, communities may want to require that a minimum area of the site remain uncleared altogether (this will depend on the land use category, with 10 or 15% as a target for commercial development, and between 25 and 50% for residential, depending on the density).
- The ESC and/or clearing/grading regulations should include a time limit for the temporary and permanent stabilization of a disturbed area. It is recommended that disturbed areas remaining idle for more than 14 days should be stabilized with hydroseeding or other appropriate stabilization measure(s). See the latest edition of the Rhode Island Soil Erosion and Sediment Control Handbook for more information (available from Soil Conservation Service, DEM Office of Environmental Coordination, or RI Resource Conservation and Development Office).
- Performance bonds should be required by communities to ensure that sites are stabilized and revegetated according to the approved plan. The ordinance should also include criteria for measuring the success of any permanent revegetation efforts. For example, a site could be considered revegetated when more than 75% of the disturbed area is stabilized.
- Clearing should be prohibited on any slope steeper than 25%. The RI Soil Erosion



and Sediment Control Handbook (1989) recommends in its model ordinance that areas with slopes exceeding 10% should be avoided if possible. For slopes 10-25%, aggressive erosion control practices should be required.

- Off-site runoff should be diverted from highly erodible soils and steep slopes to stable areas.

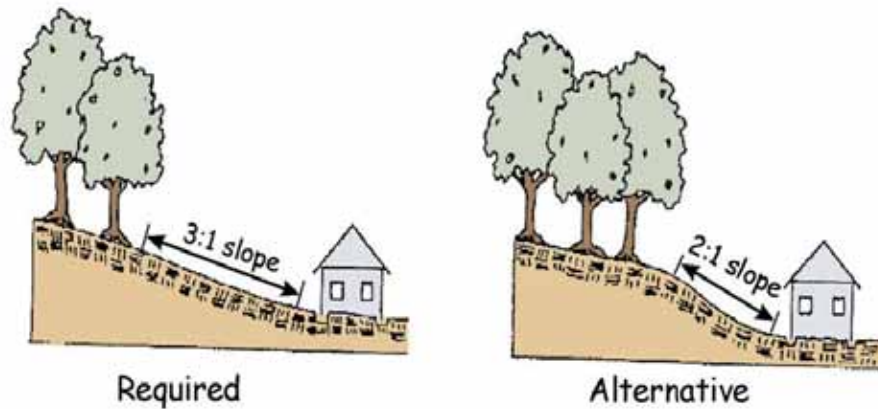
Local communities should gear any changes to ESC standards towards encouraging careful consideration of the limits of clearing and site topography during the design process to conserve as much natural area as possible. The effective use of these LID techniques will not only reduce stormwater runoff and erosion, but it can also reduce construction costs and improve the overall appearance of a development.

## Grading Ordinance Revisions

Communities could have a separate grading ordinance that incorporates the following recommended standards for prescribing maximum and minimum slopes and practices for grading development lots. These standards could also be incorporated into an ESC ordinance.

- Existing topsoil should be stored on-site and reused during final grading to the maximum extent practicable. Stockpile areas should be clearly identified on the site plan.
- As-built topographic surveys should be required for site compliance to prevent more cut and/or fill than shown on an approved site plan.
- Performance bonds should be required to ensure that sites are cleared and graded according to the approved site plan.
- Roads and structures should be located along natural contours to the maximum extent practicable.
- Grading regulations could require a maximum change of elevation at any point. Recommended values range from not more than four (4) feet.
- Communities should allow some flexibility in grading requirements to allow for decreased site footprinting. For example, some regulations require maximum lot slopes for development sites. However, variances should be allowed in some cases where installing a steeper engineered slope may actually preserve more trees and other vegetation (e.g., 2:1 vs. 3:1) and reduce the total clearing and grading (Figure 4-3). Communities should also encourage the use of well-designed retaining walls rather than extensive side slopes where grading would otherwise be necessary to achieve minimum road grades.
- Where subdivision development may be phased, communities need to have a binding ESC Plan that will carry it through the entire construction process, and include regular, high-quality inspection.

**Figure 4-3. Avoiding Impacts through Flexible Grading Standards.**



This illustration shows how grading requirements can actually lead to greater areas of disturbance. Communities should consider flexibility to allow for naturally occurring steep slopes and associated vegetation to remain in place. (adapted from MD DNR, 1991)

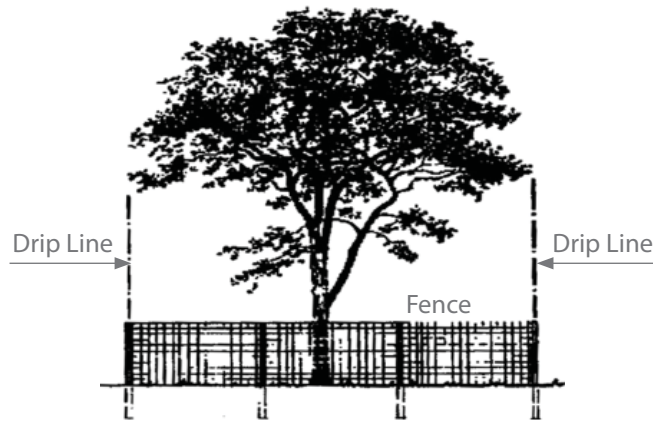
### Forest Conservation or Tree Protection Ordinances

Some communities are starting to require that trees and forests be conserved at a development site with specific ordinances and permitting processes. Tree protection standards usually focus on preserving individual trees of a certain size, while forest conservation standards have targets for preserving large stands of quality forest habitat.

- Existing stands of forest should be identified and protected before construction activity begins to the maximum extent possible.
- A woodland permit requirement should be considered for any encroachment on a forest three acres or larger.
- Soil compaction should be minimized during construction, particularly near existing trees.
- Individual large trees should be retained whenever feasible; the area within the drip line, or crown of the tree, should be fenced or roped off to protect trees and their roots from construction equipment (Figure 4-4).
- A bond should be required to cover replacement cost of trees and other vegetation earmarked for preservation when damaged by construction activities (up to two years after completion of construction). The bond should cover the cost of tree removal and replacement.
- Communities should adopt the policies and programs to implement the municipal specific forest cover targets established in the *Rhode Island Urban and Community Forest Plan State Guide Plan Element 156*.<sup>1</sup>

<sup>1</sup> For more recommendations regarding what communities can do to protect individual trees as well as forest cover, refer to the *Rhode Island Urban and Community Forest Plan* (Statewide Planning, 1999).

**Figure 4-4 Tree Protection Measured at the Drip Line.**



*Tree protection from site work must include the circumference around the entire tree canopy to the drip line. (Virginia Department of Forestry)*

### Perceptions and Realities

Some misconceptions have limited the use of site footprinting and tree preservation at a development site. By carefully crafting and revising clearing and grading language in existing regulations, a municipality can preserve more of a site in a natural state, as well as help developers save money and improve the environmental and aesthetic quality of its community.

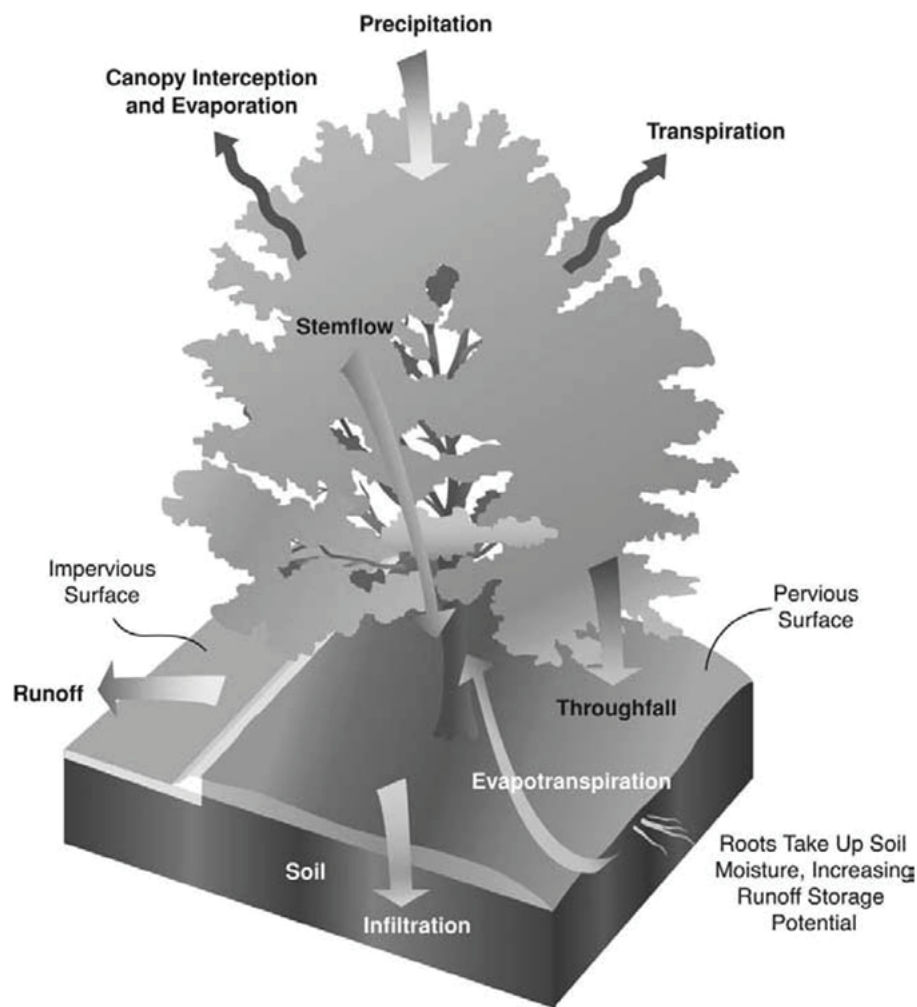
Perception	Reality
It will require more time and money for developers to selectively clear a lot.	Earth moving and ESC costs are actually reduced when clearing/grading is minimized, and as long as the no disturbance line is clearly marked, site clearing can actually be accomplished faster.
Local communities can be held responsible for damage to property from fallen trees if they adopt forest conservation or tree protection ordinances.	A community is only liable for fallen trees on municipal lands and only if the municipality is negligent in its maintenance of the property (Widener, 1997).
People prefer large expanses of lawn rather than lots with trees and other vegetation.	A study by the Maryland Department of Natural Resources (1996) showed that treed lots actually sell more quickly, and have a higher average value by 5-7%, than lots with only lawn.*

\* The Arbor Day Foundation sponsors a "Tree Benefit Calculator" that can estimate the value of trees on a particular site for stormwater, property, air quality and other values. For example a single mature beech tree in Providence, RI has an estimated value of \$200 annually. For more information go to [www.arborday.org](http://www.arborday.org).

### Stormwater Benefits

The adoption of codes to minimize clearing and grading at a development site helps to preserve the natural hydrology of the site and prevent erosion from impacting local streams, wetlands, and other environmentally sensitive areas. Preserving a site's vegetation and topography helps to maintain groundwater recharge and evapotranspiration, reducing the total volume of stormwater runoff to be managed and treated after development. The Arbor Day Foundation has estimated that a single mature beech tree in Providence, RI can intercept over 2,000 gallons of stormwater runoff annually (Figure 4-5; USDA, 2006). In addition, by preserving native vegetation on a lot, turf lawn is reduced. As a result, the quantities of fertilizers, pesticides, and irrigation water used at the site are greatly reduced, improving the quality of stormwater runoff from the lot as well as reducing costs for a business or homeowner.

**Figure 4-5 Trees and the Hydrologic Cycle.**



The Arbor Day Foundation sponsors a "Tree Benefit Calculator" that can estimate the value of trees on a particular site for stormwater, property, air quality and other values. For example a single mature beech tree in Providence, RI has an estimated value of \$200 annually. For more information go to [www.arborday.org](http://www.arborday.org). (USDA, 2006)

## Economic Benefits

A study by the Delaware Department of Natural Resources (1997) estimated that construction costs can be reduced by up to \$5,000/acre by minimizing clearing and grading at a site. In addition, total runoff is reduced by clearing less of a site, which in turn reduces the ultimate size and thus cost for post-construction stormwater management. Maintaining forests in conservation easements costs a community very little; estimates by Roser et al. (1997) indicated that it costs less than \$250/year. In addition, preserving trees and other vegetation on a site enhances property sale prices by 5 to 7% (MD DNR, 1996).

## Benefits to Community Character

Preserving a site's natural vegetation and topography can greatly improve a community's character. Various studies have shown that people prefer neighborhoods and areas with varied terrain and mature trees/forests. For example, a study by Coder (1996) showed that large old street trees were the most important indicator of community attractiveness. In addition, a survey of Seattle residents in 1990 indicated that 62% of participants listed factors such as greenery and greenbelts as what they liked best about living in the City (SEATRAN, 1998). Minimizing clearing and grading during construction can go a long way to creating healthy, aesthetically pleasing communities.

## Case Studies

### Erosion and Sediment Control

The guidance provided here for ESC uses the model ordinance provided as part of Rhode Island State enabling legislation, Title 45 Chapter 45-46-5 as its base and then provides potential modifications to increase protection. Many RI cities and towns have adopted this original model 'as is' or with minor variations, and have successfully implemented the ordinance over many years. Some have incorporated the model provisions into the zoning ordinance or subdivision and land development regulations. The modifications to the model ordinance suggested here are derived from guidance material developed by the Southern Rhode Island Conservation District and University of Rhode Island (URI) Cooperative Extension Nonpoint Education for Municipal Officials (NEMO) program. These modifications are intended to provide additional language allowing municipalities to meet the minimum requirements of the MS4. As an example of local implementation in Rhode Island that goes beyond the protections in the State model, provisions from Bristol, RI are provided below.

This guidance fills gaps from the current model in key areas such as: control of construction wastes in addition to erosion and sediment; consideration of water quality impacts in site plan review; strengthened site inspection and enforcement procedures; and coordination with State permit review and approval procedures. It should be noted that some standards of the original model ordinance are more protective than the Phase II MS4 permit requirements. In these cases, the modifications suggested within this guidance retain the same provisions as the current standard, without substituting minimum Phase II MS4 permit requirements, to provide a high level of protection.

The recommended modifications below represent the most critical changes to consider



when amending local ESC Standards. Additional modifications to consider are also available for review within the document entitled “Updating Municipal Model Erosion and Sediment Controls to Meet Phase II MS4 Permit Requirements” (August, 2009) developed by the Southern Rhode Island Conservation District and URI Cooperative Extension NEMO program. Readers interested in reviewing this document in further detail can visit the URI NEMO website: <http://www.uri.edu/ce/wq/NEMO/index.htm>

Readers interested in looking more closely at Bristol’s ESC standards can review the ordinance available on the Town’s website: <http://www.bristolri.us/>

*Model ordinance – Soil erosion and sediment control. § 45-46-5*

Modifications to ARTICLE I

- Within sub-section (b), after the text “...provisions for water disposal,...”, consider inserting the text: *construction waste management,*

Modifications to ARTICLE III

- At the end of the first paragraph, after the text “...his or her designee”, consider adding the text: *except that the following activities shall be determined to be subject to the requirements of this ordinance: all activities disturbing a total area equal to or greater than one acre, including disturbances less than one acre if part of a larger common plan; and any activity that requires permit approval by either the RI DEM or RI CRMC.*
- Within the second paragraph, before the sentence beginning with “A particular land disturbing activity,” consider inserting the text: *Where less than a total of one acre is disturbed.*
- At the end of the second paragraph, just before the sub-section beginning with “(2) This ordinance shall not apply,” consider adding the text: *In making this determination, the building official will also take into consideration the sensitivity of the water body to which the site drains. A water body and its watershed will be considered sensitive if a Total Maximum Daily Load or Special Area Management Plan is written or under development for it, or it is included on either RI DEM’s 303(d) list, or RI DEM’s list of Special Resource Protection Waters (Appendix D of the Water Quality Regulations), or it has been noted by the municipality to be of special concern.*
- In the sub-section stating “(1) Construction, alteration, or use of any additions to existing single family or duplex homes or related structures; provided, that the grounds coverage of addition is less than one thousand (1,000) square feet, and construction, alteration and use does not occur within one hundred (100’) feet of any watercourse or coastal feature, and the slopes at the site of land disturbance do not exceed ten percent (10%),” consider extending the buffer to the watercourse or coastal feature to 200 feet as in the Bristol Ordinance.

Modifications to ARTICLE IV

- Replace the first paragraph with the following language (emphasis added to show new language): To obtain approval for a land disturbing activity as found applicable by the building official or his or her designee under Article III, an

applicant shall first file an erosion and sediment control plan *if the site is less than one (1) acre in size, or if the site is a total of one (1) acre or greater in size they shall submit a Stormwater Pollution Prevention Plan (SWPPP) signed by the owner of the property, or authorized agent, on which the work subject to approval is to be performed. The plan or drawings, as described in Article V, shall include proposed erosion and sediment control and waste management measures to be employed by the applicant or the applicant's agent.*

- After sub-section (2) beginning with "(2) R.I. Freshwater Wetlands Permit," consider inserting a new sub-section (3) as follows: *(3) Construction General Permit: In those cases where a SWPPP is submitted, the applicant will also submit a copy of the Notice of Intent.*
- In sub-section (2) beginning with "(2) The time allowed for plan review," consider adding language for acknowledgement of site inspections. Bristol has added the following language at the end of sub-section (2): *The submittal of plans for review shall amount to acknowledgement and authorization from the applicant for municipal officials to enter upon and inspect private property where work is proposed for the purpose of reviewing site conditions as they relate to soil erosion, surface water runoff, and sediment control.*

#### Modifications to ARTICLE V

- Consider several modifications to insert language requiring a Stormwater Pollution Prevention Plan in all cases where the Soil Erosion and Sediment Control Plan is required. An example of such: after the sentence ending with "...requirements of this chapter," consider inserting the text: *The erosion and sediment control plan for proposed activities disturbing a total of one (1) acre or greater shall be prepared in conformance with the requirements for a Storm Water Pollution Prevention Plan (SWPPP), as provided in the RI DEM's General Permit for Storm Water Discharge Associated with Construction Activity.*
- After sub-section (2) beginning with "(2) Construction drawings," consider adding a new sub-section (3) as follows: *(3) A schedule showing the sequence of construction and inspection and maintenance of erosion and sediment control and waste control measures.*
- Within sub-section (4) beginning with "Post development runoff rates," consider adding language for additional provision for any areas of special concern. Bristol has included detailed provisions for any development/activity within the sensitive resource of the Tanyard Brook Watershed.
- Consider adding more specific requirements within sub-section (8) that currently reads, "Drainage facilities shall be installed as early as feasible during construction, prior to site clearance, if possible." Bristol has included the requirement that drainage facilities must be operational prior to increase in impervious area.
- After sub-section (12) beginning with "(12) Trees and other existing vegetation," consider inserting a new sub-section (13) as follows: *(13) Construction wastes will be managed to reduce the potential for stormwater runoff to mobilize [these wastes] and [subsequently] contaminate surface or ground water. The storage, disposal, or use as fill of material containing asphalt, concrete, construction debris or stumps, even if determined to be non-hazardous, is prohibited.*

## Modifications to ARTICLE VII

- After the first paragraph ending with "...his or her inspections," consider inserting the following text: *The owner or his/her agent shall make regular inspections of all control measures in accordance with the inspection schedule outlined on the approved Erosion and Sediment Control Plan. The purpose of such inspections will be to determine the overall effectiveness of the control plan and the need for additional control measures. All inspections shall be conducted by a properly trained professional recognized as a Certified Erosion, Sediment and Storm Water Inspector (CESSWI) by the Certified Professional in Erosion and Sediment Control (CPESC, Inc). All inspections shall be documented in written form and submitted to the building official as requested. The building official or his/her designee will perform a minimum of two (2) inspections; one during construction and one after final stabilization of the site. The developer or owner shall notify the building official of the installation of erosion and sediment control measures in order for an inspection to be performed during the construction phase of the project. The building official or his/her designee will confirm that wastes are controlled and that the erosion and sediment control practices are installed as planned, meet the needs of the site, and conform with the RI Erosion & Sediment Control Handbook.*

## Modifications to ARTICLE IX

- Consider adding the following terms and definitions:
  - o Disturbed area: An area in which the natural vegetative soil cover has been removed or altered and, therefore, is susceptible to erosion (definition from the RI Stormwater Manual).
  - o Limit of disturbance: Line delineating the boundary of the area to be disturbed during a development or redevelopment project. Area outside this boundary shall not be touched (definition from the RI Stormwater Manual).
  - o Soil amendment: Any material, such as compost, lime, animal manure, crop residues, etc., that is worked into the soil. Generally pertains to materials other than chemical fertilizers.

## City of Providence Tree Canopy Requirements

A quality model for tree canopy provisions in Rhode Island is the City of Providence. The City has adopted provisions within their zoning ordinance to protect trees and tree canopy. Chapter 1994-24 Section 425, Trees and Landscaping, requires that a minimum percentage of a lot maintains a vegetative canopy of trees. The required percentage varies by zoning district. Residential districts require at least 30% of the total lot square footage be tree canopy coverage, whereas commercial and industrial districts require at least 15% of the lot be covered. The ordinance includes specific provisions for calculating tree canopy coverage based on the type and size of trees. Parking area requirements and maintenance requirements are also provided. Readers interested in looking more closely at the landscaping and tree canopy requirements can review the City's zoning ordinance available on the City's website: <ftp://providenceplanning.org/Official%20Zoning%20Ordinance/09.06.19%20complete%20zoning%20ordinance.pdf>

## Suggested Resources

- Capiella, Karen, T. Schueler, and T. Wright. 2005. *Urban Watershed Forestry Manual: Part 1 of a 3-Part Manual Series on Using Trees to Protect and Restore Urban Watersheds*. Newtown Square, PA: USDA Forest Service, Northeastern Area State and Private Forestry.
- Coder, Kim D. 1996. *Identified Benefits of Community Trees and Forests*. University of Georgia Cooperative Extension Service, Forest Resources Unit. Publication FOR96-39.
- Corish, Kathy. 1995. *Environmental Land Planning (ELP) Series: Clearing and Grading Strategies for Urban Watersheds*. Metropolitan Washington Council of Governments, Washington, DC.
- Delaware Department of Natural Resources and Environmental Conservation (DE DNREC). 1997. *Conservation Design for Stormwater Management*. Dover, DE. 228 pp. [http://www.dnrec.state.de.us/dnrec2000/Divisions/Soil/Stormwater/New/Delaware\\_CD\\_Manual.pdf](http://www.dnrec.state.de.us/dnrec2000/Divisions/Soil/Stormwater/New/Delaware_CD_Manual.pdf).
- Maryland Department of Natural Resources (MD DNR), Forestry Division. 1991. *Forest Conservation Manual: Guidance for the Conservation of Maryland's Forests During Land Use Changes Under the 1991 Forest Conservation Act*. Annapolis, MD.
- Maryland Department of Natural Resources (MD DNR) Forest Service. 1996. *Maryland Forests: A Health Report*. Maryland Department of Natural Resources. Annapolis, MD.
- National Arbor Day Foundation. 1996. *Placing a value on trees*. Tree City USA Bulletin No. 28, Dr. James R. Fazio, Editor. Nebraska City, NE.
- National Arbor Day Foundation. 2010. *National Tree Benefit Calculator*. <http://www.arboday.org/calculator/>
- Petit, Jack, D. L. Bassert, and C. Kollin. 1995. *Building Greener Neighborhoods: Trees as Part of the Plan*. American Forests/Home Builder Press. Washington, D.C.
- Rhode Island Department of Environmental Management (RI DEM), United States Department of Agriculture (USDA) Soil [Natural Resources] Conservation Service and Rhode Island State Conservation Committee. 1989. *Rhode Island Soil Erosion and Sediment Control Handbook*.
- Rhode Island Statewide Planning. May 1999. *Rhode Island Urban and Community Forest Plan*. State Guide Plan Element 156, Report Number 97.
- Roser, K., E. Richardson and P. Bristow. 1997. *Determining the Stewardship Costs of Conservation Easements*. Colorado Coalition of Land Trusts.
- Schueler, T.R. 2000. *Clearing and Grading Regulations Exposed*. The Practice of Watershed Protection. Editors: Thomas R. Schueler and Heather K. Holland. Center for Watershed Protection. Ellicott City, MD. For purchase/registration access: <http://www.cwp.org/>
- Seattle Transportation (SEATLAN). 1998. *Seattle's Street Trees*. Seattle Department of Transportation. Seattle, WA.

- Tetra Tech, Inc (Undated). *Kentucky Erosion Prevention and Sediment Control Field Guide*. Prepared for Kentucky Division of Water, Frankfort, KY. 97 pp. <http://conservation.ky.gov/Publications/Kentucky%20Erosion%20and%20Sedimentation%20Control%20Field%20Guide.pdf>
- U.S. Department of Agriculture (USDA). November, 2006. *Piedmont Community Tree Guide: Benefits, Costs, and Strategic Planting*. 100 pp. [http://www.fs.fed.us/psw/programs/cufr/products/2/cufr\\_647\\_gtr200\\_piedmont\\_tree\\_guide.pdf](http://www.fs.fed.us/psw/programs/cufr/products/2/cufr_647_gtr200_piedmont_tree_guide.pdf)
- U.S. Green Building Council (USGBC). 2006. *LEED for New Construction Version 2.2 Reference Guide*. Washington D.C.
- Widener University Environmental Law Clinic. 1997. *Legal brief on municipal liability for fallen trees and wildfires*. Philadelphia, PA.
- Virginia Department of Forestry. 2010. *Landscape Manual for Louisa County*. <http://www.dof.virginia.gov/urban/landscape-manual.shtml>



## 5.0 LID ROADWAY DESIGN

The following sections of this chapter will examine individual elements of roadway design and make recommendations for revisiting these elements in the context of an LID approach. Each of the following elements' current practice, recommended practice, and perceptions and realities are discussed individually below:

- Travel Way (Pavement) Width;
- Right-of-Way (ROW) Width;
- Driveway Design;
- Curb Requirements;
- Sidewalk Layout and Design;
- Length and Radius of Cul-de-sacs; and
- Intersection Geometry.

This chapter includes guidance on how to develop lower impact roads in the context of national standards in an effort to reconcile some of the perceived conflicts between maintaining safety and reducing stormwater volumes.

### TRAVEL WAY (PAVEMENT) WIDTH

#### Current Practice

Road systems are typically grouped into three functional classes: arterial, collector, and local. Local roads make up about 70 percent of the total roadway mileage in Rhode Island. They convey traffic on the residential level and provide access to collector roads. Local roads receive an average of 100 to 1,500 average daily trips (ADT). The majority of this section will focus on local roads. Design standards for these roads are generally set at the local or municipal level through regulations adopted by the Planning Board/Commission. Often, these standards are based on the same guidelines used to build State or Federal highways, or on early attempts to design roads for the large-scale subdivisions that were first being planned over 50 years ago.

**Figure 5-1 Excessive Roadway Design.**



*Many communities require excessively wide roads and sidewalks that add unnecessary impervious cover and increase runoff volume. (HW photo)*

Since the birth of the exurban movement, conventional design of local roads has typically focused on the efficient movement of vehicles and vehicular safety, to the detriment of other planning objectives such as pedestrian activities, environmental concerns, cost, and community character. For example, local regulations in Rhode Island often require paved roadway widths of at least 26-28 feet irrespective of the anticipated level of traffic. This road width generally provides one slightly undersized 6-8 foot parking lane and two 10-foot travel lanes. These standards represent an appropriate design choice for larger streets with higher traffic flows, and where ample on-street parking is needed on a regular basis. However, in less densely populated areas or for lower ADTs, these wide stretches of pavement are over-designed and create a number of problems:

- Vehicle speeds can increase, posing a safety risk to both drivers and pedestrians;
- Capital expenditures for construction and maintenance are unnecessarily high;
- Larger ROWs increase clearing and reduce the amount of land available for tax-generating development; and
- Larger impervious areas increase stormwater runoff volumes and flow rates, reduce groundwater infiltration, and increase pollutant loads, especially where curb-and-gutter stormwater systems are used to manage stormwater.

## Objective

Residential streets should be designed to be as narrow as possible based on future traffic volumes without compromising safety.

## Recommended Practice

Roadways should be wide enough to accommodate travel lanes, regular on-street parking (where required), and the passage of emergency vehicles, school buses, and the occasional

delivery truck. Many local standards will specify that local urban roads shall be paved to a width of between 28 and 32 feet, while local rural roads might have a standard of 22 feet in width. These guidelines are appropriate for high-density development or higher vehicle volumes but are generally excessive for most suburban and rural developments. For example, the American Association of State Highway and Transportation Officials (AASHTO) recommends that a two-lane rural road traveled at 25 mph should be 18 feet wide. They suggest urban roads should be 20 to 28 feet wide for low-density developments and 28 to 34 feet wide for medium density developments, depending on street parking requirements (AASHTO, 2001; ITE, 1997), though the higher values of these ranges should be viewed as conservative in most situations. Despite this, many municipalities continue to have local codes or regulations in place that discourage or even prohibit impervious cover reductions. Table 5-1 provides some typical road width reduction standards that communities should consider adopting.

**Table 5-1 Example of Road Travel Widths for Local Streets.**

Minimum Road	Parking	Average Daily Trips (ADT)	Number of Dwellings Units Served
20	Parking on both sides*	< 200	20
22	Parking on one side*	200-400	20-40
26	Parking on both sides	400-2,000	40-200
28	Parking on one side	> 2,000	> 200
32	Parking on both sides	> 2,000	> 200

\*Parking is restricted to one side during a snow emergency. No parking is permitted if road is a designated fire lane.

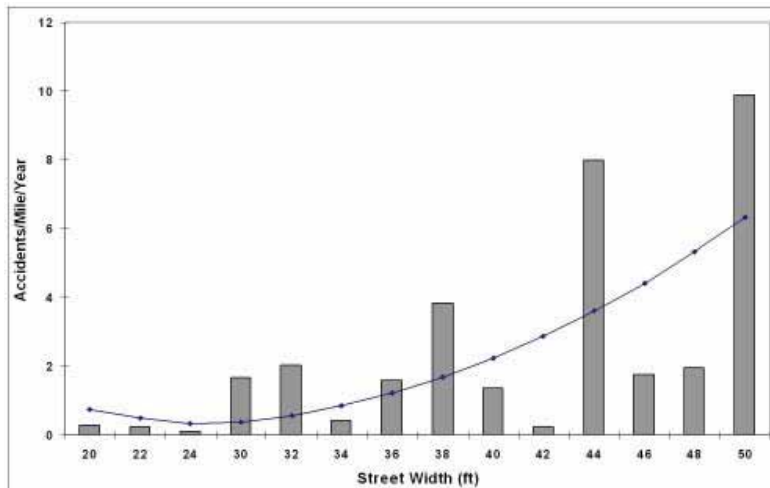
## Perceptions and Realities

One of the most difficult discussions that occurs at the local level involves the perceived conflict between LID roadway design and issues of safety and access. While many local planners or developers may promote smaller roadways and open section drainage, other local officials or citizens may see these designs as “unsafe” for pedestrians or insufficient for emergency situations. This challenge has been the subject of considerable research in recent years.

### Street Width and Safety

As discussed in the section above, for ROW width, a common misconception is that wide streets are necessary for pedestrian safety; however, it has been cited that narrower streets slow traffic, which allows drivers more time to react and prevents potential accidents (FHA, 1997; ITE, 1997; ULI, 1992). Figure 5-2 displays the results of a study that demonstrates the relationship between street width and accident occurrences in Longmont, Colorado.

**Figure 5-2 Relationship Between Street Width and Accidents in Longmont, CO.**



As street widths increase so do accident rates. (Swift, et al., 1998 as in CWP, 1998)

## Fire Safety

Sufficient street width must be provided for emergency vehicle access; yet, the conventional perception that significantly wide streets are needed to ensure adequate access for emergency vehicles, particularly fire vehicles, is often excessive. Table 5-2 provides representative LID example street width requirements for fire vehicles.

**Table 5-2 Street Width Requirements for Fire Vehicles. (CWP, 1998)**

Width (feet)	Source
18-20 <sup>1</sup>	US Fire Administration
24 (on-street parking) 16 (no on-street parking)	Baltimore County Fire Department
18 minimum	Virginia State Fire Marshall
24 (no parking) 30 (parking on one side) 36 (parking on both sides) 20 (for fire truck access)	Prince Georges County Department of Environmental Resources
18 (parking on one side) <sup>2</sup> 26 (parking on both sides)	Portland Office of Transportation

<sup>1</sup> Represents typical "fire lane" width, which is the width necessary to accommodate a fire vehicle.

<sup>2</sup> Applicable to grid pattern streets or short cul-de-sacs.

## On-Street Parking Demand

Often, wider residential streets are justified by the need to provide on-street parking. However, providing a continuous parking lane on both sides of the street is an often inefficient and expensive way to satisfy the required parking for residential areas, since most of the required parking per unit can be met within driveways. The additional on-street parking lanes increase the street's impervious cover and create unutilized parking capacity; however, if one or both of the on-street parking lanes also served as a traffic lane (i.e., a queuing street), both traffic movement and parking needs could be met by a narrower street.

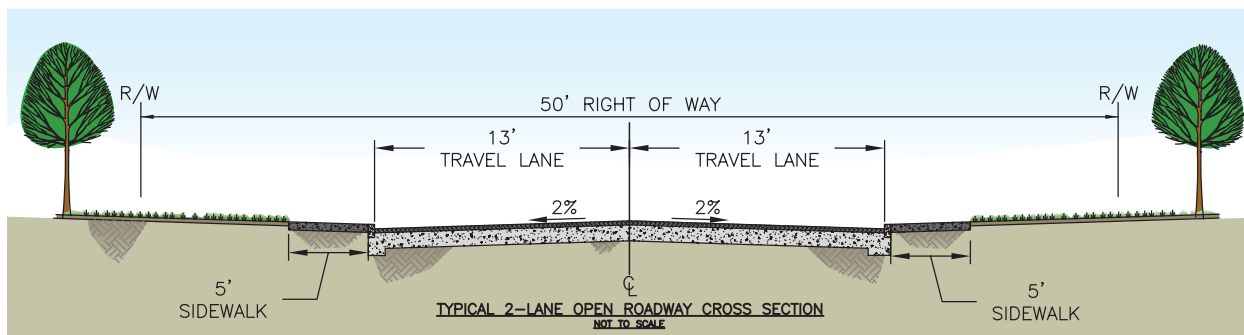
Perception	Reality
Wide streets are necessary for pedestrian safety.	Narrower streets slow traffic, which allows drivers more time to react and prevent potential accidents (FHA, 1997; ITE, 1997; ULI, 1992).
Significantly wide streets are needed to ensure adequate access for emergency vehicles, particularly fire vehicles.	Current standards are typically excessive (CWP, 1998).
Wider residential streets are justified by the need to provide on-street parking.	Providing a continuous parking lane on both sides of the street is an often inefficient and expensive way to satisfy the required parking for residential areas, since most of the required parking per unit can be met within driveways.

## RIGHT-OF-WAY (ROW) WIDTH

### Current Practice

The ROW is the total land area that contains all elements of a public or private road such as pavement, utilities, sidewalks, shoulders, and drainage. Therefore, this area must be wide enough to enclose all of the cross-sectional features of the roadway, including the pavement width, curbing, buffers, sidewalks, utilities, drainage, and grading. The Institute of Traffic Engineers (ITE) guidelines recommend a minimum ROW width of 50 feet for low-density development and 60 feet for medium and high-density developments (ITE, 1997). Consequently, a ROW width between 50 and 60 feet is a common design choice throughout the country. Unfortunately, this standard often leads to the “over design” of roadways in rural or other sparsely developed areas and leads to clearing, grading, and paving that may not be necessary.

**Figure 5-3 Typical Suburban Roadway Cross-Section.**



*This cross-section shows how a typical suburban road is over-designed with a 50-foot ROW, 26 feet of pavement, and sidewalks on both sides of the street. (HW graphic)*



## Objective

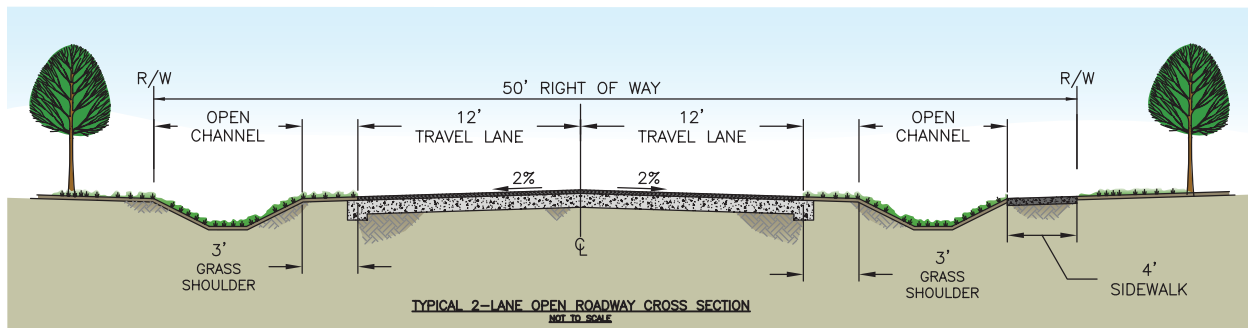
Residential ROW should be kept to the minimum width needed to safely accommodate travel lanes, pedestrians, and vegetated open channels. In addition, utilities and storm drains should be located within the pavement section of the ROW wherever feasible.

## Recommended Practice

The standard ROW width of between 50 and 60 feet can be excessive in many situations. Wide ROWs reduce the amount of land that may be developed and increase the amount of clearing and grading that must occur to construct the road, creating negative environmental and economic effects. The ROW need only be wide enough to contain all of the cross-sectional elements. These elements may include sidewalks, utility easements, parking lanes, drainage features, and travel lanes depending on the size, density and location of the development.

More moderate standards for ROW construction may include a 44- to 50-foot ROW width for 26- to 30-foot wide local urban and suburban streets. In a rural setting, it is not uncommon to see slightly reduced standards such as a 40-foot ROW for 22-foot wide local roads. For example, for two nine-foot paved lanes with five-foot sidewalks that are offset six feet from the road and one foot from the edge of the property lines, the ROW may be as narrow as 42 feet. Similar reductions can be made for higher-order streets. ROW widths of 24 to 52 feet are practical for many applications. Table 5-3 provides examples of narrower ROWs for residential streets.

**Figure 5-4 Suburban Roadway Cross-Section with LID Design.**



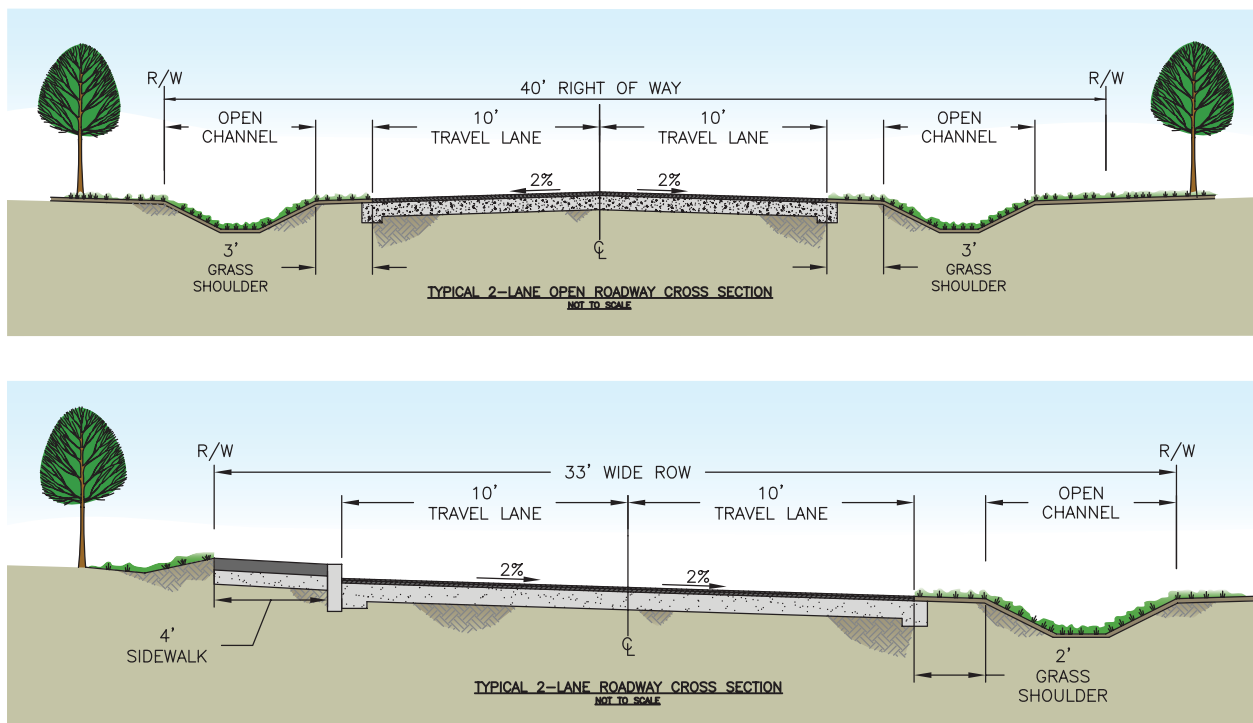
*This cross-section shows how the same road from Figure 5-3 can be modified with a smaller travel lane, roadside swales and a single sidewalk. (HW graphic)*

**Table 5-3 Examples of Narrower ROW Widths. (CWP, 1998)**

Source	ROW Width (feet)	Pavement Width (feet); Purpose
Portland, Oregon	35 40	20; residential street 26; residential street
Montgomery County, Maryland	20 44 46-60	16; residential alley 20; residential street 26; residential street
ASCE 1990 (Recommendation)	24-26 42-46	22-24; residential alley 26; residential street

When considering all of the potential elements that increase the width of a ROW, it may be helpful to consider innovative approaches to roadway design. For example, allowing utilities to be placed beneath the paved section of the street would allow for reduced ROW widths and may also create space along the edge of the ROW for conveying stormwater through open channels. Open channels can be used to meet water quality treatment requirements in the RI Stormwater Manual when designed according to the criteria in Chapter 5. Also, the use of geo-textile treatments along shoulders can provide for emergency pull-off or parking and subsequently reduce the need for larger ROW widths.

**Figure 5-5 Rural Roadway Cross-Sections with LID Design.**



These cross-sections show different approaches to low traffic roads. Each has a significantly smaller ROW and paved travel surface. Both incorporate LID drainage with slightly different approaches to grading. (HW graphics)

## Perceptions and Realities

### One Size Fits All

Many communities perceive that a “one size fits all” approach to roadway development provides a more efficient approach to land development that is more advantageous to both developers and local authorities. However, the opposite is true. Using only one or two acceptable ROW layout standards significantly limits the opportunity to design roadways that answer to site-specific conditions and constraints, future traffic volumes, and goals for innovative site design.

### Utility Maintenance

It is common for communities to install water and sewer lines beneath the pavement section when constructing new roads. Eventually these utilities will need to be accessed for repair or replacement, whereby traffic may be temporarily impeded, and utility companies will incur additional costs for repaving the roadways. The amount of pavement needed to be removed during these operations can be decreased through better diagnostic tests and trenchless technologies for utility construction and repair.

Perception	Reality
Many communities perceive that a “one size fits all” approach to roadway development provides a more efficient approach to land development that is more advantageous to both developers and local authorities.	Using only one or two acceptable ROW layout standards significantly limits the opportunity to design roadways that answer to site-specific conditions, future traffic volumes, and goals for innovative site design.
When underground utilities need to be accessed for repair or replacement, traffic may be temporarily impeded, and utility companies will incur additional costs for repaving the roadways.	The amount of pavement needed to be removed during these operations can be decreased through better diagnostic tests and trenchless technologies for utility construction and repair.

## DRIVEWAY DESIGN

### Current Practice

Most suburban driveways create from 400 to 800 square feet of impervious cover, or enough space to park two to four cars. Generally, local subdivision codes are not explicit as to how driveways should be designed, specifically regarding dimensions and surface material. Typically, the single lane driveway for a residential home is 10 to 12 feet wide and 18 to 20 feet wide for homes with two-car garages. Most driveways are constructed of concrete or asphalt. Subdivision codes also indirectly influence the length of the driveway when excessive front yard setbacks, which dictate how far houses must be from the street, are required (CWP, 1998).

Shared driveways are usually discouraged or sometimes even prohibited in local codes. This

is primarily because there is a concern that multiple homeowners may not be able to agree on the long-term maintenance of the driveway (CWP, 1998).

## Objective

Lot impervious cover should be reduced to the maximum extent practicable by minimizing driveway lengths, encouraging alternative pervious surfaces, and allowing shared driveways wherever possible.

## Recommended Practice

Driveways must be wide enough to allow for the passage of vehicles and long enough to satisfy parking requirements. Typically, a 10-foot wide driveway is more than sufficient for one vehicle, while 20-foot wide driveways are often used for two-car garages connected directly to the street (ITE, 1997). Widths of nine feet may be sufficient for each automobile lane depending on the location of the driveway relative to the structure. Driveways should always be designed with proper slopes, sight distances, and radii.

One way to reduce the total amount of impervious area required by driveways in a development is to use shared driveways. These are privately owned and maintained driveways, typically 12 to 16 feet wide. Shared driveways also provide fewer curb cuts and therefore increase safety. Careful design can provide sufficient space for overflow parking while reducing the overall area required. Important considerations for shared driveways include:

- The maximum allowable number of homes that may be served by a common driveway. Typical standards range from two to six homes.
- The type of shared driveway covenant that will be used by the homeowners to ensure that maintenance responsibilities are clearly described and adequately enforced.
- Depending on the number of homes served, there is the potential for locating larger shared features such as mail repositories and trash removal pads at the end of the driveway. Communities may wish to include design specifications for these areas to ensure aesthetic appeal and the reduction of potential nuisances.

Impervious cover associated with driveways can also be reduced by relaxing front yard setbacks. Flexible setback requirements allow for more creativity in site planning and development, and allow for more compact lots and greater open space. **See Chapter 2, Conservation Development.**

Material selection can also reduce driveway impervious cover. There are several alternative driveway surfaces available that reduce impervious cover and provide increased infiltration. Table 5-4 compares the durability, performance, and cost of alternative paving materials.

**Table 5-4 Summary of Issues Related to Various Types of Alternative Pavements. (BASMAA, 1997 as in CWP, 1998; updated based on RI DEM/CRMC, 2010 and UNHSC, 2009)**

Material	Initial Cost	Maintenance Cost	Water Quality Effectiveness*
Conventional Asphalt / Concrete	Medium	Low	Low
Pervious Concrete	High	High	High
Porous Asphalt	High	Medium	High
Turf Block	Medium	High	High
Brick	High	Medium	Medium
Natural Stone	High	Medium	Medium
Concrete Unit Pavers	Medium	Medium	Medium
Gravel	Low	Medium	Medium
Wood Mulch	Low	Medium	High
Cobbles	Low	Medium	Medium

\*Relative effectiveness in meeting stormwater quality goals

## Perceptions and Realities

### Shared Driveway

One of the more common perceptions relative to shared driveways that can deter this approach is the risk of conflicts between owners. In areas where routine maintenance such as snow removal is required, local officials fear conflicts between property owners that could become difficult to manage and cause disruption in the neighborhood. Further, depending on the working schedules of different homeowners, many people are concerned with the ability of homeowners to “come and go as they please” for fear that parked cars close to the driveway entrance will preclude access.

Although these concerns are valid, proper design can mitigate many of the conflicts that would otherwise occur. For example, if a shared driveway is long enough to accommodate a few automobiles on both sides, the entranceways can be designed toward the recommended minimum width of 12 feet as it is unlikely any cars would be regularly parked at the mouth of the driveway. However, where a shared driveway is only long enough to accommodate two parked cars for each owner, the entranceway to the driveway will need to be designed in a wider configuration to allow adequate access.



**Figure 5-6 Shared Driveway.**



*This shared driveway eliminated over 1,000 linear feet of pavement, used only one curb cut on a busy road, and eliminated the need to run a driveway through a scenic field. (S. Millar)*

## **Alternative Surfaces**

Contrary to popular belief with regard to function of LID stormwater practices in harsh winter climates, the University of New Hampshire Stormwater Center (UNHSC) collected over four years of data that demonstrate that LID strategies, including pervious pavers, function well in cold climates. Research at UNHSC also shows that permeable pavement reduces dependence on salt for deicing roads and parking lots. Although the use of road salt can be imperative for safety during hazardous winter road conditions, there is currently no adequate treatment practice for road salt, which is damaging to our waterways. Over the course of two winters, and 38 storms, the UNHSC researchers analyzed the performance of an on-site porous asphalt parking lot and observed solid performance with regard to plowing capability and reduced road salt demand (UNHSC, 2009).

In addition, some developers are concerned that alternative driveway surfaces are less marketable than conventional paving materials. However, the use of these alternative materials, such as pervious pavers, is being sought out by a range of customers (Ewing, 1996). In addition, aesthetically pleasing alternative driveways (e.g., brick pavers), although more expensive, are highly marketable.

There is a common misperception that alternative driveway surfaces may limit disability access. Although the Americans with Disabilities Act (ADA) requires accessible routes on firm and stable surfaces to and between public facilities, single family homes do not necessarily have to meet this requirement. In addition, developers can choose to provide some houses with conventional paving or select alternative surfaces that will not be an impediment to those with disabilities.

## **Front Yard Setbacks**

There are several misconceptions related to front yard setbacks. One mistaken belief is that decreased setbacks and shorter driveways do not provide enough parking spaces. However,

the average number of vehicles per household is 1.66, which can typically be accommodated between the driveway, garage, and on-street parking (Pisarski, 1996).

Another issue raised regarding decreased front yard setbacks is that it will reduce drivers' sight distance, or the length of roadway that can be easily viewed. However, sight distance impediments can be avoided by placing visual obstructions (e.g., garages, front porches) at least two feet back from the curb. This setback is far less than the 30-foot setback required by many jurisdictions (AASHTO, 1994; CWP, 1998).

**Figure 5-7 Traditional Village Setbacks.**



*This photo illustrates how traditional New England villages rely upon small setbacks to connect residents to the street and create a more compact neighborhood development. (DEM, 2010)*

The concern that decreasing the front setback will increase traffic noise is also often unwarranted. Traffic noise is mostly a function of traffic speed, and there are many traffic calming strategies that can be implemented to decrease the speed of cars, such as narrower streets (AASHTO, 1994; FHA, 1996).

Perception	Reality
<p>In areas where routine maintenance such as snow removal is required, local officials fear conflicts between property owners could become difficult to manage and cause disruption in the neighborhood.</p>	<p>Proper design can mitigate many of the conflicts that would otherwise occur between different homeowners. For example, if a shared driveway is long enough to accommodate a few automobiles on both sides, the entranceways can be designed toward the recommended minimum width of 12 feet as it is unlikely any cars would be regularly parked at the mouth of the driveway.</p>

Alternative surfaces do not function well in cold climates.	The UNHSC collected over four years of data demonstrating that LID strategies, including pervious pavers, function well in cold climates (UNHSC, 2009).
Decreased setbacks and shorter driveways do not provide enough parking spaces.	The average number of vehicles per household is 1.66, which can typically be accommodated between the driveway, garage, and on-street parking (Pisarski, 1996).
Decreased front yard setbacks will reduce drivers' sight distance, or the length of roadway that can be easily viewed.	Sight distance impediments can be avoided by placing visual obstructions (e.g., front porches) at least two feet back from the curb.
Decreasing front yard setbacks will increase traffic noise.	Traffic noise is mostly a function of traffic speed, and there are many traffic calming strategies that can be implemented to decrease the speed of cars, such as narrower streets (AASHTO, 1994; FHA, 1996).

## CURB REQUIREMENTS

### Current Practice

Although curbing provides boundary and guards against erosion of roadway edge, hard continuous curbs deter infiltration. Curbing is an integral part of a closed drainage system, effectively delivering stormwater runoff to drainage collection basins. Vertical curbing is most commonly used in urban areas and is recommended by ITE for all medium- to high-density developments (ITE, 1997). Rolled curbing, or asphalt berm, is less expensive and is recommended for use in medium to low-density developments. While vertical curbing provides some protection for pedestrians, rolled curbing allows for on-street parking using part of the shoulder (WA DOT, 1997). Design specific to the site's density of vehicular and pedestrian traffic, sight lines, slope, and infrastructure for traffic management should guide the use of curbs or softer edge. However, using curbing in all areas of a site will likely remove opportunities to channel water into surface BMPs such as swales or bioretention systems.

**Figure 5-8 Typical Residential Curb Design.**



*This photo shows how continuous curbing directs runoff into over-sized stormwater facilities that provide poor water quality treatment. (HW photo)*

## Objective

Curbs in streets should be eliminated wherever possible to allow road drainage into open channel systems.

## Recommended Practice

Despite the apparent efficiencies associated with raised curbing, there are several disadvantages to using this design approach, particularly relative to LID implementation. One disadvantage to curbing is cost; it is much more expensive to build a road with curbs and a closed drainage system than one with vegetated shoulders and open swales. Curbs also prevent stormwater runoff from infiltrating along the side of the road, and create concentrations of pollutants, such as debris, sediments, and bacteria. As a result, more runoff occurs with higher pollutant concentrations on curbed streets. In addition, curb-and-gutter conveyance systems quickly carry stormwater to downstream water bodies, increasing peak flows that can cause flooding and erosion problems. Where practical, curbing should be eliminated and open drainage swales should be used in lieu of closed drainage systems. In *Rural By Design*, Randal Arendt recommends that curb-and-gutter systems only be used where higher densities prohibit the use of swales (four or more units per acre), or where roadside erosion is a concern due to steep slopes of eight percent or more (Arendt, 1994).



**Figure 5-9 Residential Swale.**



*Vegetated swales are used to manage runoff from adjacent roads instead of having typical “curb and gutter” systems. (HW photo)*

## Perceptions and Realities

One common argument against eliminating curbs is that it may increase the potential for surface erosion or failure of the road surface at the pavement edge. However, these effects can be mitigated by hardening the pavement grass interface through the use of grass pavers or a low-rising concrete strip (CWP, 1998). The use of such a strip also increases the visibility of the roadway edge, enhancing traffic safety at night. Another common concern from residents is that open drainage is unattractive, difficult to maintain, and may pose a health risk from standing water. While these are challenges with open drainage, they can all be addressed by careful design of the swale system following the criteria in the RI Stormwater Manual. Dry swales can be used that are designed without standing water and maintained similar to adjacent lawn. In addition, a bioswale system could be utilized that actually improves the aesthetic characteristic of the community.

Perception	Reality
Eliminating curbs may increase the potential for surface erosion or failure of the road surface at the pavement edge.	These effects can be mitigated by hardening the pavement grass interface through the use of grass pavers, or a low-rising concrete strip (CWP, 1998).
Open drainage is unattractive, difficult to maintain, and may pose a health risk from standing water.	While these are challenges with open drainage, they can all be addressed by careful design of the swale system following the criteria in the RI Stormwater Manual.



## SIDEWALK LAYOUT AND DESIGN

### Current Practice

Several Rhode Island communities require a five-foot sidewalk on each side of the street regardless of traffic volumes. This design standard is consistent with ITE guidance which recommends four- to six-foot sidewalks offset one foot from the edge of the ROW on both sides of the street for medium- and high-density developments (ITE, 1997). Typically, the width requirement for a sidewalk is increased if it is constructed adjacent to the edge of the roadway, buildings, or shrubs (Burden, 1999).

#### **Figure 5-10 Typical Suburban Sidewalk Design.**



*This photo shows how conventional subdivisions often incorporate 5-foot sidewalks on both sides of the street adding unnecessary impervious cover. (CWP)*

### Objective

Flexible design standards should be adopted that are based on safe pedestrian movement and limiting impervious cover.

### Recommended Practice

Sidewalks can enhance community character by providing a safe place for people to walk and play. However, sidewalks are costly and increase the total impervious area of a development, so requirements for these amenities must also be weighed against concerns for reducing impacts from impervious surfaces.

It is important for local practitioners to consider that constructing five-foot sidewalks on both sides of the street is not always appropriate, even in medium- to high-density developments. In *Better Site Design*, for example, a three- to four-foot sidewalk on one side of the street is proposed for many situations (CWP, 1998). Where practical, sidewalks should be graded to drain into front lawns, reducing the total amount of runoff generated by the

roadway. Alternative surfaces such as permeable asphalt or gravel could be considered where appropriate. Walkways may also be removed from the roadway entirely and used to provide access to natural features or connect other destinations, such as a playground, park or adjacent development. At low design speeds (10 to 15 miles per hour), sidewalks may be integrated with the road surface (Burden, 1999).

**Figure 5-11 Residential Pathway.**



*This photo shows an unpaved pedestrian path within a residential subdivision. This site design technique provides a low impact alternative to impervious sidewalks placed in the right-of-way. (RI DEM, 2003)*

## Perceptions and Realities

In an attempt to create healthier, walkable neighborhoods, many communities feel that requiring sidewalks on both sides of a street is necessary and is safer for pedestrians so that they do not need to cross the street. However, by implementing crosswalks and speed bumps (or other traffic calming devices) for access to sidewalks on only one side of the street, communities can also achieve lower, and thus safer, speeds in residential areas. Another misconception is that all residents want sidewalks on both sides of the street; however, while some residents do prefer to have access to a sidewalk, others do not. There is no appreciable market difference between houses that are directly served by sidewalks (i.e., the sidewalk is on the same side of the street), and houses not directly served (i.e., sidewalk is on the opposite side of the street; Woodsmall, 1998).

In many neighborhoods, the safest option would be to relocate the pedestrian path away from the street altogether. Many times, the places that residents would like to walk to (commercial centers, local stores, parks, etc.) are in a different direction than the subdivision road. In these cases, walkways that directly connect residential areas to points of interest would be much more effective at promoting exercise and reducing traffic, while also reducing the amount of directly connected impervious area along the roadway.

Others feel that roads without sidewalks on both sides of the street are a legal liability and/or do not meet ADA requirements. However, careful design and policy implementation protects governments and professionals from undue liability (NHI, 1996). The ADA requires at least one accessible route from public streets, parking areas, and passenger loading zones along a route that generally corresponds with that of the general public. There are no specific restrictions on roadway sidewalks.

Perception	Reality
Requiring sidewalks on both sides of a street is necessary and is safer for pedestrians so that they do not need to cross the street.	By implementing crosswalks and speed bumps (or other traffic calming devices) for access to sidewalks on only one side of the street, communities can also achieve lower, and thus safer, speeds in residential areas.
All residents want sidewalks on both sides of the street.	There is no appreciable market difference between houses that are directly served by sidewalks (i.e., the sidewalk is on the same side of the street), and houses not directly served (i.e., sidewalk is on the opposite side of the street; Woodsmall, 1998).
Roads without sidewalks on both sides of the street are a legal liability and/or do not meet ADA requirements.	Careful design and policy implementation protects governments and professionals from undue liability (NHI, 1996).

## LENGTH AND RADIUS OF CUL-DE-SACS

### Current Practice

In the past, most residential streets were developed in a grid-like pattern, with the majority of streets being through-ways. After World War II, however, cul-de-sacs became a prominent feature in new residential subdivisions (Nielsen, 2006). Cul-de-sacs are residential streets that are open at one end and closed, or come to a dead-end, at the other. A large “bulb” is located at the closed end to allow vehicles, including emergency and service vehicles, to turn around without having to back up. Many communities require that the bulb be 50 to 60 feet or more in radius, which creates a large circle of impervious cover that is never fully realized for turning movements (CWP, 1998).

**Figure 5-12 Typical Over-sized Cul-de-sac.**



*Excessive cul-de-sac requirements increase runoff volume and add to community costs for maintenance. (Bing Maps)*

## Objective

The dimension, design, and surface material of cul-de-sacs should be modified to reduce total impervious cover.

## Recommended Practice

Lanes and ways terminating in a cul-de-sac offer lower vehicle flows and speeds, increasing a sense of privacy in residential development. However, such dead end streets offer reduced access in the time of an emergency and can increase the total impervious area of a development. There are three overall options to reduce impervious cover associated with cul-de-sacs:

1. Reducing the size or radius;
2. Use of a pervious center island (i.e., native vegetation or engineered bioretention system); and
3. Alternative design, such as “hammer head” or “loop road.”

A cul-de-sac must be wide enough to accommodate the turning radii of large vehicles such as fire trucks and school buses. Many communities have interpreted this need as requiring radii of 50 to 60 feet, which can result in paved areas over 11,000 square feet just for the turning portion of the roadway. Newer fire trucks have reduced turning radii, and the paved radius may therefore be reduced to 30 to 40 feet in some cases (ASCE, 1990).

The impervious area can also be minimized by creating a vegetated area in the center, provided that a sufficient paved width is maintained (ITE recommends a minimum of 25 feet). This landscaped island can also be used to receive and treat stormwater to meet water quality requirements. For example, the island can be designed as a bioretention area using the



criteria in the RI Stormwater Manual. Other, more passive approaches to landscape cul-de-sacs include widening the radius to leave significant areas of natural vegetation or to provide landscaped amenities (Figure 5-13).

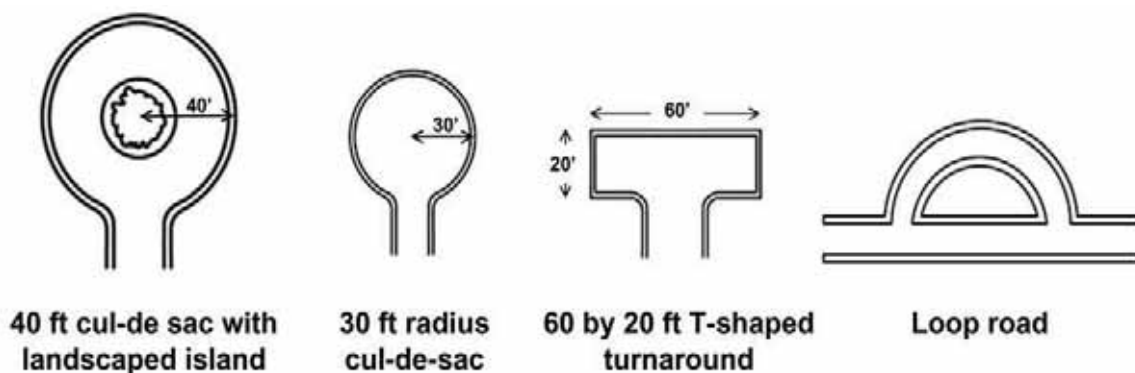
**Figure 5-13 Examples of Landscaped Islands.**



*Vegetated cul-de-sacs reduce impervious cover and provide a neighborhood landscape feature. (J. West, left; S. Millar, right)*

Alternative layouts, such as a tee- or hammer-shaped turnaround, may be appropriate for streets shorter than 200 feet in length. These areas offer significant reductions in impervious area over the standard cul-de-sac. A loop road is also a good option; these provide multiple access points for emergency vehicles and can carry double the traffic volume of a cul-de-sac. Loop roads also favor the construction of tee-style intersections, which offer numerous benefits.

**Figure 5-14 Alternative Terminus and Loop Designs.**



*(Adapted from Schueler, 1995)*

In addition, building narrow streets with sharper turns is a preferable alternative to cul-de-sacs, since it can accomplish the same goal of reducing traffic disturbances, while maintaining essential connectivity between neighborhoods. Where cul-de-sacs must be built, they are generally designed for a maximum of 200 ADT. This is approximately equal to the traffic generated by 20 to 25 houses at eight to 10 trips per day. Depending on the density of the development, ITE recommends maximum cul-de-sac lengths between 700 and 1,500 feet (ITE, 1997).



## Perceptions and Realities

The majority of community concerns related to minimizing the size of cul-de-sacs are that school buses and emergency vehicles require a large turning radii. However, many newer fire trucks and other service vehicles have turning radii of 30-40 feet (CWP, 1998). In addition, school buses typically do not enter cul-de-sacs, but pick up the students at one pre-arranged location.

Another misconception is that homeowners prefer the isolated appeal of cul-de-sacs. This appeal can also be obtained by tee- and hammer-shaped turnarounds, or by utilizing loop roads, with an overall result of reduced impervious area.

Perception	Reality
School buses and emergency vehicles require a large turning radii.	Many newer fire trucks and other service vehicles have turning radii of 30-40 feet (CWP, 1998). In addition, school buses typically do not enter cul-de-sacs, but pick up the students at one pre-arranged location.
Homeowners prefer the isolated appeal of cul-de-sacs.	This appeal can also be obtained by tee- and hammer-shaped turnarounds, or by utilizing loop roads, with an overall result of reduced impervious area.

## INTERSECTION GEOMETRY

### Current Practice

An intersection is a road junction where two or more roads meet or cross at grade. The most common intersection is a four-way intersection which involves the crossing of two roads. In most current four-way intersections, the crossing streets are perpendicular to each other, forming 90 degree angles. Often times, four-way intersections are designed to be far wider than necessary.

### Objective

Intersections should be designed to be pedestrian friendly and minimize impervious cover.

### Recommended Practice

Larger intersection curb radii minimize lane encroachments by turning vehicles, but lead to an increase in costs, impervious cover, and vehicle speeds. Wide intersections also create an environment that is less friendly to the pedestrian. Curb radii should be set to the minimum size required by turning vehicles and lane configurations. AASHTO recommendations are sufficient for the purposes of efficient and safe travel and range from 15 feet for smaller roads

to 25 feet for collector streets (AASHTO, 2001). Community officials must provide adequate flexibility within their local codes to allow designers to assign the appropriate radius to proposed intersections depending on anticipated traffic volumes and goals for managing impervious surfaces.

**Figure 5-15 Example of “Unfriendly” Intersection Design.**



*Intersections that are unfriendly to pedestrians are often characterized by wide expanses of pavement with no “safe place” for people to stand as they attempt to cross more than one lane of traffic.  
(HW photo)*

**Figure 5-16 Example of Pedestrian Friendly Intersection.**



*Intersections that use alternative surfaces to delineate walking spaces as well as raised islands provide a much safer separation between automobiles and pedestrians.  
(HW photo)*

When considering actual intersection design, many local codes make it very difficult to design something other than large scale 90-degree cross intersections. Tee-style intersections offer a number of advantages over crosses, and should be used where practical. Tee intersections tend to be safer (ITE, 1997), provide attractive terminating vistas, decrease vehicle speeds, and reduce points of pedestrian-vehicle conflict (Burden, 1999). In order to minimize conflict between adjacent intersections, tees should be spaced a minimum of 125 feet apart (ITE, 1997). A sub-collector road with a number of loop roads terminating in tee-style intersections offers a good opportunity to minimize impervious cover, enhance pedestrian safety, and reduce vehicle speeds, while increasing the overall flow of traffic.

## Perceptions and Realities

Some communities believe that all intersections should have wide radii and be 90-degree cross intersections to ensure the safety of their residents. However, as stated above, narrower radii and tee intersections actually promote slower speeds and increase pedestrian safety. By providing a designer flexibility in intersection design for a specific site, a community can decrease impervious area while maintaining or improving the safety and aesthetic appeal of the neighborhood.

Perception	Reality
All intersections should have wide radii and be 90-degree cross intersections to ensure the safety of their residents.	Narrower radii and tee intersections actually promote slower speeds and increase pedestrian safety.

## SUMMARY

### Benefits

#### Stormwater Benefits

Adopting codes that limit the amount of impervious area required for roadways contributes greatly to better stormwater management. With reduced impervious area, the quantity and peak flow of runoff from a neighborhood is greatly reduced. In addition, by allowing flexibility in terms of the drainage network system (curb-and-gutter vs. open section), greater infiltration and water treatment can be achieved throughout a development.

#### Economic Benefits

By adopting the recommended standards for roadway design, costs can be reduced for both developers and local municipalities. Decreasing the total amount of pavement, curbing, sidewalks, and storm sewer infrastructure required for a development can greatly decrease the construction costs for a developer. As discussed under pavement width, construction costs for paving are approximately \$15 per square yard. Reduced impervious cover will also save communities money, since there will be less impervious surfaces to maintain and plow in the winter (CWP, 1998).

**Example:** A local jurisdiction currently requires all residential streets with one parking lane to be a minimum of 28 feet wide. The jurisdiction adopts a new standard: 18 feet wide queuing streets. This new standard would reduce the overall imperviousness associated with a 300 foot road by 35% and construction costs by \$5,000 (CWP, 1998).

In addition, vegetated stormwater practices, such as bioretention areas or open channel drainage, throughout a neighborhood are far less expensive than an extensive catch basin/manhole/pipe system that discharges to a large, fenced off stormwater management practice. The cost of a curb and gutter / storm drain pipe system typically ranges from \$40 to \$50 per

running foot, which is about 2 to 3 times more expensive than an engineered swale (SMBIA, 1990; CWP, 1998).

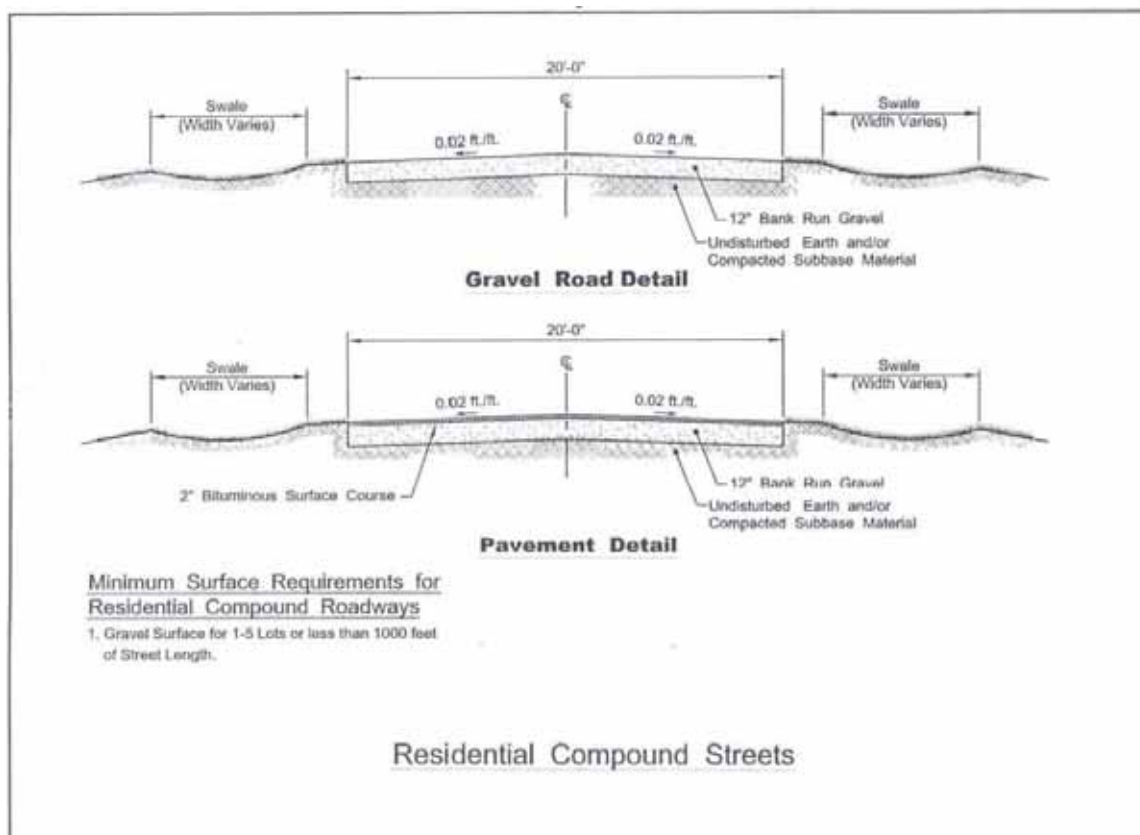
Increased vegetation, narrower streets, destination walkways, and a variety of turnaround styles can also increase the appeal of a neighborhood, and thus, the overall sales price (CWP, 1998).

## Case Studies

### Town of Burrillville

The Town of Burrillville has adopted roadway design standards (Burrillville Subdivision and Development Plan Review Regulations: Chapter X, Section 10) that are anticipated to have a much lower impact than conventional standards. The Town has five street classifications depending on what is being developed and the Town has reduced pavement widths for non-village and local roads equal to 22 feet. The community also requires different sidewalk widths based on the road classification. As can be seen in the Town's detail plan for residential compound streets, below, there is a specification for open section drainage.

**Figure 5-17 Town of Burrillville Residential Compound Street Cross-Section.**



(Town of Burrillville Subdivision Regulations)

## **Town of Barrington**

The Town of Barrington road standards illustrate some very basic examples of how communities can begin implementing more refined and site specific approaches to roadway design. As one example, Chapter 200-44.F of the Subdivision Regulations allows streets in minor developments and subdivisions to have a paved surface of 22 feet within a 40-foot ROW. These values demonstrate that decreases can be effective for lower traffic streets, which would be very common in many communities for new development.

In subsection J of the same chapter, Barrington also allows for alternatives to cul-de-sac configurations that can significantly reduce impervious cover:

“Temporary turnarounds or those at the end of short streets or alleys serving minor developments or subdivisions may be in the form of a “T” or a “Y” (also referred to as a “hammerhead”). A “T” or a “Y” shaped turnaround shall have a minimum length of sixty (60) feet and minimum width of twenty (20) feet, with a right-of-way extending ten (10) feet beyond the paved area.”

## **Town of Exeter**

The Town of Exeter provides a brief and simple example of how to review street widths on a case-by-case basis, which can be extremely useful to rural communities that face unique issues relative to traffic speed and smaller roads that may be subject to larger vehicle traffic. The simple language found in Section 7.2.B.9 of the Exeter Land Development and Subdivision Regulations allows the Planning Board to consider all the different factors associated with a new roadway by stating:

“...street pavements shall be 18 to 24 feet in width, as determined by the planning board, measured between curbs or edge of pavement.”



## Suggested Resources

American Association of State Highway and Transportation Officials (AASHTO). 1994. *A Policy on Geometric Design of Highways and Streets, 5th Edition*. Washington, DC. For purchase: <https://bookstore.transportation.org/>.

American Association of State Highway and Transportation Officials (AASHTO). 2001. *Guidelines for Geometric Design of Very Low-Volume Local Roads (ADT ≤ 400)*. Washington, DC. For purchase: <https://bookstore.transportation.org/>.

American Society of Civil Engineers (ASCE). 1990. *Residential Streets, 2nd Edition*. National Association of Home Builders and Urban Land Institute. Washington, D.C. For purchase: <http://www.asce.org/>

Arendt, Randall, E. Brabec, H. Dodson, C. Reid, and R. Yaro. December, 1994. *Rural by Design: Maintaining Small Town Character*. Planners Press, American Planning Association. 441 pp.

Bay Area Stormwater Management Agencies Association (BASMAA). January 1997. *Start at the Source: Residential Site Planning and Design Guidance Manual for Stormwater Quality Protection*. 8 pp. [http://www.ccleanwater.org/Publications/StartAtTheSource/toc\\_testimonials\\_howtousebook.pdf](http://www.ccleanwater.org/Publications/StartAtTheSource/toc_testimonials_howtousebook.pdf).

Burden, Dan, M. Wallwork, K. Sides, R. Trais, H.B. Rue. 1999. *Street Design Guidelines for Healthy Neighborhoods*. Local Government Commission Center for Livable Communities. Sacramento, CA. For purchase: <http://www2.lgc.org/bookstore/>

Caraco, D. and R. Claytor. 1997. *Stormwater BMP Design Supplement for Cold Climates*. Center for Watershed Protection. Elliot City, MD. For purchase/registration access: <http://www.cwp.org/>

Center for Watershed Protection (CWP). 1995. *Site Planning for Urban Stream Protection*. Ellicott City, MD. For purchase/registration access: <http://www.cwp.org/>

Center for Watershed Protection (CWP). 1998. *Better Site Design: A Handbook for Changing Development Rules in Your Community*. Prepared for the Site Planning Roundtable. Ellicott City, MD. 172 pp. For purchase/registration access: <http://www.cwp.org/>

Center for Watershed Protection (CWP). 2000. *Better Site Design: An Assessment of the Better Site Design Principles for Communities Implementing the Chesapeake Bay Preservation Act*. Prepared for the Chesapeake Bay Local Assistance Department. Ellicott City, MD. For purchase/registration access: <http://www.cwp.org/>

Ewing, R. 1996. *Best Development Practices: Doing the Right Thing and Making Money at the Same Time*. American Planning Association, Chicago, IL.

Federal Highway Administration (FHA). 1996. *Pedestrian and Bicycle Crash Types of the Early 1990's*. U.S. Department of Transportation. Washington, DC. FHWA-RD-95-163.

Federal Highway Administration (FHA). 1997. *Flexibility in Highway Design*. U.S. Department of

Transportation, Washington, DC. Publication No. FHWA-PD-97-062.

Grava, Sigurd. 2003. *Options Beyond Inflated Local Street Standards*. Urban Planning Program, Graduate School of Architecture, Planning, and Preservation at Columbia University. New York, NY.

Institute of Transportation Engineers (ITE). 1997. *Guidelines for Residential Subdivision Street Design*. Washington, DC. For purchase: <http://www.ite.org/>

National Fire Protection Administration (NFPA). 2005. *NFPA 1 Uniform Code*. Prepared by the Technical Committee on Uniform Fire Code. Las Vegas, NV. For purchase: [http://www.nfpa.org/catalog/category.asp?category\\_name=Codes+and+Standards&Page=1](http://www.nfpa.org/catalog/category.asp?category_name=Codes+and+Standards&Page=1)

National Highway Institute (NHI). 1996. *Pedestrian and Bicyclist Safety and Accommodations*. U.S. Department of Transportation, Federal Highway Administration, National Highway Traffic Safety Administration, Maclean, VA. Publication # FHWA-HI96-029.

Nielsen, John. June 7, 2006. *Cul-de-Sacs: Suburban Dream or Dead End?* National Public Radio. <http://www.npr.org/templates/story/story.php?storyId=5455743>

Pisarski, A.E. 1996. *Commuting in America II: The Second National Report on Commuting Patterns and Trends*. ENO Transportation Foundation, Inc.

Rhode Island Department of Environmental Management (RI DEM). 2003. *Rhode Island Conservation Development Guidance Manual*. 96 pp. <http://www.dem.ri.gov/programs/bpoladm/suswshed/pdfs/condev.pdf>.

Rhode Island Department of Environmental Management (RI DEM) and Coastal Resources Management Council (CRMC). December, 2010. *RI Stormwater Design and Installation Standards Manual*. <http://www.dem.ri.gov/programs/benviron/water/permits/ripdes/stwater/t4guide/desman.htm>

Suburban Maryland Building Industry Association (SMBIA). 1990. *Unpublished data on the unit cost of residential subdivision development in suburban, Maryland*.

Swift, Peter, Dan Painter, and Matthew Goldstein. 1998. *Residential Street Typology and Injury Accident Frequency*. Swift and Associates, Longmont, CO.

University of New Hampshire Stormwater Center (UNHSC). 2009. *2009 Biannual Report*. 36 pp. [http://www.unh.edu/erg/cstev/pubs\\_specs\\_info/2009\\_unhsc\\_report.pdf](http://www.unh.edu/erg/cstev/pubs_specs_info/2009_unhsc_report.pdf)

Urban Land Institute (ULI). 1992. *Density by Design (DBD)*. James W. Wetling and Lloyd W. Bookout, editors. Washington, DC.

Washington State Department of Transportation (WA DOT). September, 1997. *Pedestrian Facilities Guidebook*. 247 pp.

Woodsmall, D. L. 1998. *Personal Communication*. Natelli Communities. Gaithersburg, MD.

## 6.0 LID PARKING GUIDANCE

Across the State of Rhode Island for several decades, patterns of development have reflected both the mobility and convenience provided by the car and generally the strict separation of land uses required by many zoning codes. To successfully manage the auto-dependent environment in which we live, we rely on safe, plentiful, accessible, and usually free parking at all of our destinations. A central issue facing our communities is that their current parking standards require too many spaces and do not allow developers enough flexibility in terms of innovative approaches to parking. Parking lots are a major contributor to impervious cover and the environmental impacts of altered hydrology that can occur from the construction of too many parking spaces.

As developers attempt to meet the parking requirements of their projects, many find themselves locked into a set of standards that provide significant disincentives for considering better site design alternatives. Parking is certainly required to keep our business community viable and our residential neighborhoods safe, but it is necessary today to re-think parking design, parking finance, and parking supply and demand to help meet many planning objectives, including those for reducing impacts from stormwater runoff. This chapter discusses the essential regulatory strategies and tools relative to parking that can be used to establish and maintain a human-scaled environment that emphasizes parking efficiency over supply and provides excellent opportunities for reducing impervious cover. The current practice, recommended practice, and perceptions and realities for each of the following techniques are discussed individually below:

- Parking Ratios in Zoning Ordinances;
- Shared Parking;
- Off-Site Parking Allowances;
- Stall and Aisle Geometry; and
- Parking Lot Landscaping.

### PARKING RATIOS

#### Current Practice

Most communities' parking requirements are based on parking ratios, or a set minimum number of parking spaces per unit, for each designated land use (e.g., one space per 1,000 square feet of commercial space; one space per three seats for restaurants; or two spaces per bed for hospitals). Although minimum parking ratios are usually clearly defined within a community's zoning code, maximum parking ratios are not. Parking ratios typically represent the minimum number of spaces needed to accommodate the highest hourly parking at the site (Wells, 1995). Parking demand refers to the number of spaces actually used for a particular land use (ITE, 1987). Table 6-1 provides a comparison of conventional parking requirements and average parking demand for some example land uses.

**Table 6-1 Typical Parking Requirements Compared with Observed Demand. (CWP, 1998)**

Land Use	Parking Requirement		Actual Average Parking Demand
	Parking Ratio	Typical Range	
Single Family Homes	2 spaces per dwelling unit (d.u.)	1.5 – 2.5	1.11 spaces per d.u.
Shopping Center	5 spaces per 1,000 sq ft GFA <sup>1</sup>	4.0 – 6.5	3.97 per 1000 sq ft GFA
Convenience Store	3.3. spaces per 1,000 sq ft GFA	2.0 – 10.0	--
Industrial	1 space per 1,000 sq ft GFA	0.5 – 2.0	1.48 per 1,000 sq ft GFA
Medical/Dental Office	5.7 spaces per 1,000 sq ft GFA	4.5 – 10.0	4.11 per 1,000 sq ft GFA

<sup>1</sup>Abbreviated GFA refers to the gross floor area of a building, without storage and utility spaces.

**Figure 6-1 Typical Oversized Parking Lot.**



*Many commercial uses have an excessive amount of parking which detracts from community character. (S. Millar)*

## Objective

Communities should establish both minimum and maximum parking ratios to provide adequate parking while reducing excess impervious cover.

## Recommended Practice

The most direct way for local planners to more appropriately control the supply of parking is by revising or “tailoring” local zoning ordinances to more accurately reflect local parking demand and circumstances. Rather than imposing inflexible requirements, local zoning ordinances should look to incorporate mechanisms that tailor parking requirements to specific development projects. Reductions could be allowed for factors such as: mixed land uses, access to alternative transportation, demographics, and utilization of Transportation Demand Management (TDM) Programs including subsidized mass transit and parking cash out programs. Such reductions could fluctuate depending on the conditions around the site so the best approach is to allow flexibility within the regulations and subsequently require the

developer to demonstrate the appropriate amount of parking needed. Any parking reduction would ultimately require review and approval by a municipal review committee.

When tailoring parking standards, communities should consider concurrently requiring a *maximum* parking requirement that restricts the total number of spaces allowed at a development site. A potential strategy for setting a maximum parking requirement is for each community to consider using its current minimum parking ratio as the new maximum requirement as was done several years ago in the Town of Exeter, RI. However, in many cases, these requirements could still be too high and each community will need to tailor these maximums through discussions with their planning and permitting agencies to get a sense of what is appropriate in each district. Some examples of tailored parking requirements are provided in the North Kingstown case study material later in this chapter.

Regardless of how the minimum and maximum values are calculated, communities should provide applicants with a range of parking values. As data and additional information are collected, potentially through parking surveys, communities may need to revise their maximum parking allowance to meet their minimum number. Initially, and in absence of locally relevant data and experience, providing a range of options to developers allows them to examine the efficiency that best suits their business and also provides more meaningful development space.

In addition to reducing the parking standards, pervious materials can be used for parking areas and/or overflow parking areas to reduce the total impervious area, and increase recharge. Pervious pavers can replace conventional asphalt or concrete, and can range from medium to relatively high effectiveness in meeting stormwater quality goals. The different types of alternative pavers include gravel, cobbles, wood mulch, brick, grass pavers, turf blocks, natural stone, pervious concrete, and porous asphalt. In general, alternate pavers require proper installation and more maintenance than conventional asphalt or concrete (SMRC, 2010 ; RIDEM, 2010).

**Figure 6-2 Pervious Overflow Parking in West Hartford, CT.**



*Regular parking areas are constructed with asphalt (background) while overflow areas show pervious travel lanes and reinforced turf in the foreground of this photo. (HW photo)*



## Perceptions and Realities

The general perception regarding parking requirements is that the public's interest is best served by adopting a conservative approach to minimize the likelihood of an undersupply of spaces. In an effort to provide more than enough parking to satisfy the public's need, local planners have traditionally relied upon minimum parking ratios as the primary tool to regulate parking. However, these ratios are typically not derived from an analysis of local parking needs. Instead, parking ratios are often drawn from those of neighboring communities or from the parking generation rates and standards that are published by the Institute of Transportation Engineers (ITE). In one such commonly used publication, *Parking Generation*, the parking generation rates are derived from a small number of studies that measure peak parking demand at suburban locations, where parking is free and there is no public transit (Shoup, 2005). As a result of applying these generic parking standards minimum parking ratios tend to be overly conservative and inflexible, leading to more parking than is necessary.

Another misconception regarding parking standards is that lenders will be hesitant to fund development proposals that they perceive do not have enough parking to be viable. Although this may be the case for a small group of land uses or lenders, discussions with close to a dozen reputable banks in Rhode Island reveal that these lenders were not only amenable to limiting parking supply, but also encouraged the practice as it potentially increased the amount of viable building space that would produce revenue.

A third common misconception regarding parking supply is that large supplies of ample free parking are necessary for business viability and therefore contribute to a community's fiscal bottom line by strengthening the tax base. In fact, overdevelopment of parking areas consumes valuable land area that could be used to expand viable business and increase tax dollars generated per unit of land. Optimizing the amount of active commercial space should be the priority for designated growth areas and excessive parking requirements will be one of the most influential obstacles toward achieving that goal. Further discussion of fiscal impacts associated with excessive parking requirements can be found in Litman, 2006.

Perception	Reality
The public's interest is best served by adopting a conservative approach to minimize the likelihood of an undersupply of spaces.	As a result of applying typical generic parking standards, minimum parking ratios tend to be overly conservative and inflexible, leading to more parking than is necessary.
Lenders will be hesitant to fund development proposals that they perceive do not have enough parking to be viable.	Discussions with close to a dozen reputable banks in Rhode Island reveal that these lenders were not only amenable to limiting parking supply, but also encouraged the practice as it potentially increased the amount of viable building space that would produce revenue.

Large supplies of ample free parking are necessary for business viability and therefore contribute to a community's fiscal bottom line by strengthening the tax base.	Overdevelopment of parking areas consumes valuable land area that could be used to expand viable business and increase tax dollars generated per unit of land.
---	--

## SHARED PARKING

### Current Practice

As discussed in the Parking Ratios section above, typically parking lots are designed based upon pre-established ratios for each land use, regardless of whether adjacent land uses can share parking areas or not. Although only a limited number of communities have taken advantage of the strategy, shared parking can significantly reduce the number of required parking spaces needed by allowing adjacent land uses to share parking lots. This arrangement is possible when peak demands for the adjacent land uses occur at different times during the day or week.

### Objective

Shared parking should be encouraged and implemented wherever feasible in order to reduce total impervious cover associated with parking areas.

### Recommended Practice

Shared parking can be defined as parking utilized jointly among different buildings and facilities in a single area to take advantage of different peak parking characteristics that vary by time of day or day of the week. Since most parking spaces are only used part time, shared parking arrangements are designed to more efficiently meet the needs of areas that exhibit a mix of uses with varying peak parking demands. For example, many businesses or government offices experience their peak business hours during the daytime on weekdays, while restaurants and bars peak in the evening hours and on weekends. This presents an opportunity for shared parking arrangements where several different groups can use an individual parking lot without creating conflicts.

There is a considerable amount of planning needed to determine the appropriate number of parking spaces under shared parking arrangements. Table 6-2 shows a typical approach to calculating shared parking requirements and illustrates that a simple peak demand analysis can significantly reduce the combined requirements for office and retail use sharing parking space. In this example, the combined minimum requirements in zoning are 370 spaces, while the demand analysis shows an actual requirement of 286 spaces: a 23% reduction.

**Table 6-2 Example Shared Parking Calculation. (Adapted from Montgomery County, MD)**

	OFFICE USE			RETAIL USE			Parking Requirement by Time Period
	Minimum Parking Requirement	Percentage of Parking Requirement	Adjusted Parking Requirement	Minimum Parking Requirement	Percentage of Parking Requirement	Adjusted Parking Requirement	
Weekday Daytime	160	100%	160	210	60%	126	286
Weekday Evening	160	10%	16	210	90%	189	205
Weekend Daytime	160	10%	16	210	100%	210	226
Weekend Evening	160	5%	8	210	70%	147	155
Nighttime	160	5%	8	210	5%	10.5	18.5

An alternative approach to shared parking is to allow an applicant to submit their own analysis showing the peak parking demands that will occur at different times within a proposed development to determine the appropriate number of spaces. (The Urban Land Institute published guidance on how to perform these analyses in their *Shared Parking*, 2nd Edition, 2005.) Since changes in ownership, operations, or use might alter parking demand in the future, many ordinances that allow for shared parking require contingency plans to accommodate additional parking that may be necessary in the future. Another important consideration for shared parking arrangements is to ensure that the ordinance allows for parking requirements to be met through off-site parking facilities. This topic will be discussed in further detail in the following section.

## Perceptions and Realities

There is a widespread perception that shared parking arrangements are overly complex to implement and create additional challenges when making changes to ownership, operations, or uses. In many cases, it is simply that municipal officials and property owners have not received enough exposure to shared parking arrangements to understand the potential advantages over conventional parking calculations. A comprehensive study performed in Portland, OR, for example, demonstrates that many businesses in the region were successfully using shared parking agreements while other business owners were unaware of these relationships and skeptical of the approach (Portland Metro, 1997). Municipal officials must educate their Town Council regarding the merits of these programs and gain the support of their Solicitors from a legal perspective. An example Shared Parking Ordinance produced by the Capitol Region Council of Governments can be found in the References section at the end of this chapter.

Perception	Reality
Shared parking arrangements are overly complex to implement and create additional challenges when making changes to ownership, operations, or uses.	Municipal officials and property owners have not received enough exposure to shared parking arrangements to understand the potential advantages over conventional parking calculations.

## OFF-SITE PARKING ALLOWANCES

### Current Practice

Current regulations in most communities today require all new development and redevelopment to provide all parking on-site. Rarely can off-site parking availability be counted. This can make it difficult, if not impossible, for many redevelopment sites and compact mixed use centers to comply with conventional on-site parking demands.

### Objective

Communities should increase the flexibility of parking requirements and include off-site parking allowances under certain development scenarios.

### Recommended Practice

An integral piece to providing adequate flexibility within parking regulations involves allowing on-site parking requirements to be met through off-site facilities. These off-site allowances are particularly important in redevelopment sites and compact mixed use centers where lot geometry and pre-existing development patterns can make it impossible for existing structures to comply with conventional on-site parking demands. Allowing business owners to negotiate with each other across property boundaries encourages a more integrated private sector approach and a much more efficient use of land. Recommended zoning provisions for off-site parking include the following:

- Establishing design standards that require well-marked, safe pedestrian travel from the parking lot to the target site (e.g. improvements to sidewalks, lighting, crosswalks, and crossing signals between the site and pedestrian and vehicular access points at the off-site parking location).
- Establishing a maximum distance that the parking lot may be from the target site. Typical values range from 350 – 1,000 feet (walking distance). Before settling on a value for this maximum distance, communities should use maps to get a sense of where existing parking lots are situated relative to other buildings. Unnecessarily strict maximum distances may provide barriers to quality redevelopment.

**Figure 6-3 Signage for Shared Parking**



*This sign illustrates how the innovative parking ordinance in North Kingstown allows commercial operations to share parking facilities. (HW photo)*

Finally, a condition of any approval should be a legally defensible agreement between property owners that guarantees access to the parking lot, outlines any shared maintenance agreements, and addresses issues of shared liability.

### Perceptions and Realities

The perception regarding the location of parking supply is that parking should be located in close proximity to the use that is utilizing the spaces. While this is an understandable approach to regulate parking, the application of strict requirements that all parking must be located within the boundaries of the site can be problematic, particularly in the context of commercial redevelopment and compact mixed use areas. Many municipalities struggle with innovative development plans that seek to break the mold of traditional strip development patterns but cannot move forward as a result of inflexible parking standards.

Perception	Reality
Parking should be located in close proximity to the use that is utilizing the spaces.	Application of strict requirements that all parking must be located within the boundaries of the site can be problematic, particularly in the context of commercial redevelopment and compact mixed use areas.

## STALL AND AISLE GEOMETRY

### Current Practice

The parking stall, generally referred to as a parking space, can vary in size but typical dimensions are as much as 10 feet wide and 20 feet long. The parking aisle refers to the travel



lane within a parking facility that allows for cars to reach the parking stalls. Parking aisles are typically 12 feet wide and parking facilities normally have two-way traffic resulting in 24 feet of travel space between opposing parking stalls.

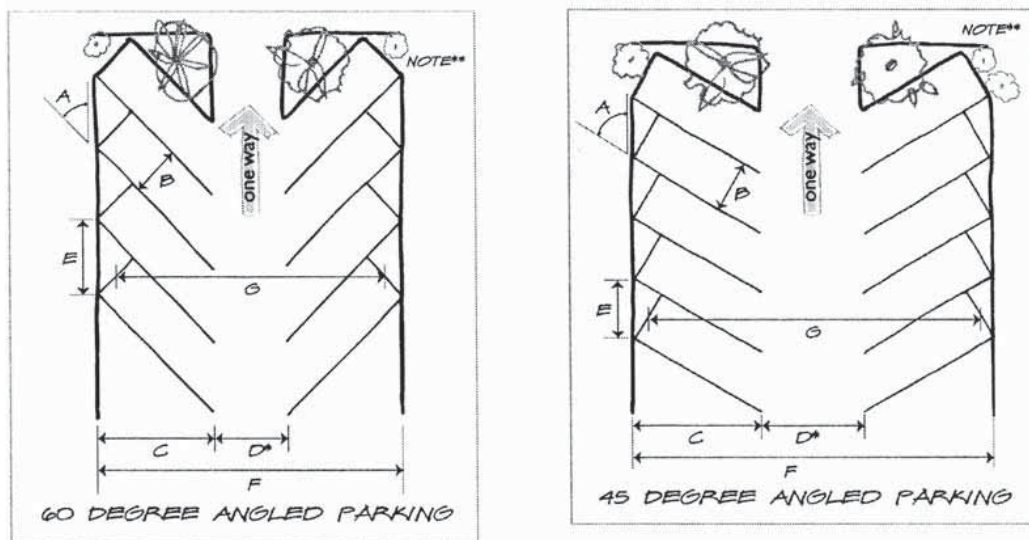
## Objective

Parking stalls and aisles should be reduced to the extent feasible in order to decrease total impervious cover.

## Recommended Practice

A minor reduction in parking stall dimensions can result in a significant impact on the overall size of a parking lot. Reducing stall dimensions to 9 feet wide and 18 feet long would result in a 28% reduction in the stall area compared to the more typical 10 feet by 20 feet stall. Additionally, encouraging one-way aisles used in conjunction with angled parking may reduce the amount of aisle space needed to access each stall, depending on the geometry of the parking lot. Local municipalities should carefully assess their existing parking dimensions and existing parking lots before considering reductions to parking stall and aisle dimensions. If broad changes to parking dimensions are not the best fit for a community, another option is to allow for a portion of parking lots to be comprised of compact car spaces. Compact car spaces can be provided as 8 feet by 16 feet stalls. The most important element of a successful compact car parking space program is providing a clear system of signage that indicates which spaces are intended for compact cars and which are not.

**Figure 6-4 Angled Parking Design Options**



Depending on the lot, using angled parking and one-way drive aisles may reduce the total impervious area. ([http://search.municode.com/html/13725/level3/SURE\\_ART15PA\\_DIV4DECOMA.html](http://search.municode.com/html/13725/level3/SURE_ART15PA_DIV4DECOMA.html))

## Perceptions and Realities

One of the major challenges in addressing the dimensional standards of parking stalls and aisles is the perception that larger vehicles will not fit into smaller parking stalls. Many

communities fear that limiting stall and aisle dimensions will result in cramped conditions in parking facilities. However, this perception does not often meet with reality as the majority of larger vehicles, such as sport utility vehicles (SUVs) and vans can comfortably fit into smaller stalls without the risk of damaging other vehicles or conflicting with pedestrian needs.

Perception	Reality
Limiting stall and aisle dimensions will result in cramped conditions in parking facilities.	The majority of larger vehicles, such as sport utility vehicles (SUVs) and vans can comfortably fit into smaller stalls without the risk of damaging other vehicles or conflicting with pedestrian needs.

## PARKING LOT LANDSCAPING

### Current Practice

While many communities require parking lot landscaping, they do so in a manner that supports aesthetics and tree canopy cover, but not always in a manner that supports stormwater management. For example, many communities require a certain number of landscaped islands per parking space or a specific spacing of trees within the lot. Landscaping within a parking lot can serve a variety of functions such as aesthetics, canopy cover, and stormwater management. Providing relief mechanisms in the ordinance for these situations will allow the engineers the freedom to design a treatment system that is tailored to the unique geometry and topography of a given lot.

**Figure 6-5 Example of Poorly Designed Parking Lot Landscaping.**



*Small isolated raised beds of vegetation do nothing to manage stormwater and often succumb to stresses associated with traffic and snow management. (HW Photo)*

## Objective

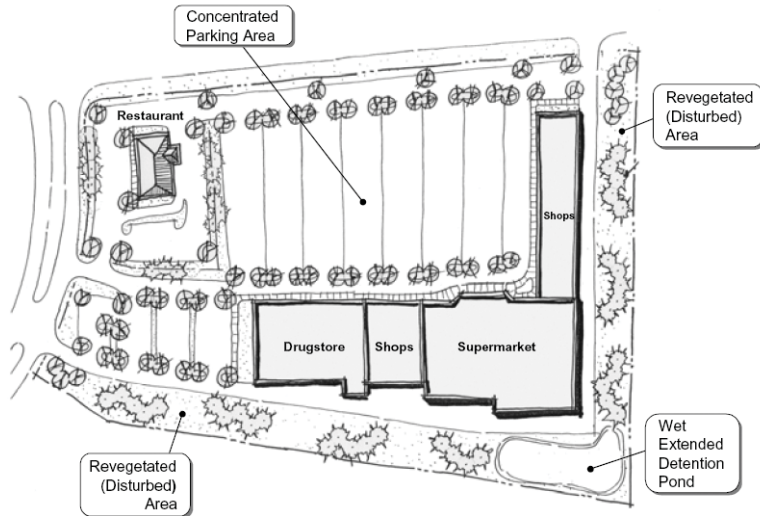
Communities should relax parking lot landscaping standards in cases where applicants seek to include LID techniques for managing stormwater runoff.

## Recommended Practice

LID facilities such as open section drainage, vegetative swales, and bioretention basins exhibit unique design characteristics that can be difficult to fit into a regimented landscaping formula. The following is a series of recommended practices regarding innovative approaches to parking lot landscaping:

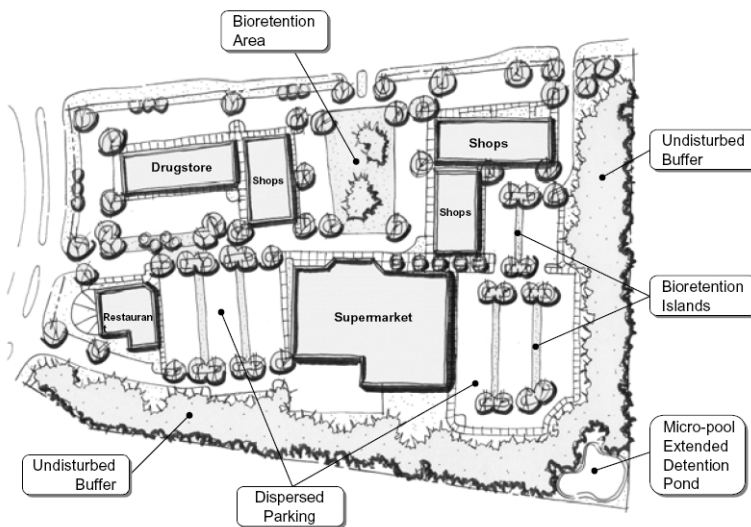
- Use of open section drainage to encourage sheet flow to open channels where pollutants are removed through infiltration and natural filtering prior to discharge. This approach is described in detail within the RI Stormwater Manual and provides a much more effective means of managing stormwater than using conventional “curbed” drainage systems.
- Use of vegetative swales to direct stormwater into shallow bioretention areas that temporarily detain the water to allow for partial infiltration while pretreating the remaining stormwater before it is discharged into waterways.
- For parking lots of 10 or more spaces, require that 10% of parking lot area be dedicated to landscaped areas that can include LID stormwater practices. **A more detailed discussion of landscaping practices and plant selection is provided in Chapter 8, LID Landscaping.**
- Mandate landscaping within parking areas that “breaks up” pavement at fixed intervals. Case studies included with this chapter provide examples of how landscaped islands can be required at fixed frequencies. It is important to provide relief from these frequencies when a developer wishes to use landscaping as part of stormwater management practices so that they can have the flexibility necessary to adequately site and design vegetated BMPs.
- Consider requiring a minimum amount of tree canopy coverage over on-site parking lots. Many municipalities use this standard for aesthetics and to mediate the urban heat island effect. Requirements generally range between 25% and 30% canopy coverage.

**Figure 6-6 Schematic of Conventional Parking Layout.**



Conventional parking designs clear the entire site, that later needs to be revegetated, and creates one massive area for parking. (Georgia Stormwater Manual, 2001)

**Figure 6-7 Schematic of Parking Layout Using LID Techniques.**



The LID design leaves undisturbed buffers of native vegetation, incorporates landscaped islands that treat stormwater, and disperses the parking into smaller areas. (Georgia Stormwater Manual, 2001)

Local communities should carefully consider any changes to parking lot landscaping standards with an eye to increasing flexibility and providing references to the RI Stormwater Manual. The effective use of LID techniques not only reduces stormwater runoff, it can also reduce construction and maintenance costs by 25-30% compared to conventional “curbed” drainage approaches.

## Perceptions and Realities

Many municipalities perceive parking lot landscaping standards as something that should

be regimented and measured, such as requiring a certain number of landscaped islands per parking space or a specific spacing of trees within the lot. While this approach may be helpful for providing consistency in terms of appearance, it can also hinder innovative designs that seek to utilize landscaping as part of an integrated stormwater management system.

Perception	Reality
Lot landscaping standards should be regimented and measured, such as requiring a certain number of landscaped islands per parking space or a specific spacing of trees within the lot.	This approach can provide consistency in terms of appearance, but can also hinder innovative designs that seek to utilize landscaping as part of an integrated stormwater management system.

## SUMMARY

### Benefits

#### Stormwater Benefits

Adopting codes that both limit the amount of parking spaces required for land development activities and also enhance the designs of these areas contributes greatly to better stormwater management. By reducing the number of required spaces, more flexible parking standards can reduce the amount of impervious surface being developed for both residential and non-residential development.

#### Economic Benefits

Zoning ordinances that require excessive amounts of parking for non-residential use are one of the primary causes of commercial sprawl including strip malls, outdated office parks and oversized retail parking lots. These developments miss a significant economic potential and can fall short of meeting the tax base needs of their host communities (Litman, 2006 p.237). Providing flexible parking standards is one of the more important tools to reducing this wasteful pattern of development and optimizing the economic potential of non-residentially zoned land.

#### Benefits to Community Character

Reducing parking requirements and enhancing design standards for parking areas can contribute to the revitalization of commercial areas and their overall aesthetic appeal. Replacing vast unbroken expanses of asphalt with smaller, well-landscaped parking areas provides a much more appealing development style and enhances the designer's ability to provide more organized circulation and pedestrian connectivity.

### Case Studies

There are several municipalities in Rhode Island today that employ innovative approaches to regulating parking. These municipalities have adopted a variety of standards that help to



limit impervious surface and increase economic development potential where appropriate. Below are three examples of communities that have experienced success with innovative standards.

## **Exeter**

Over five years ago, the Town of Exeter implemented one of the most straightforward approaches to limiting parking supply in their community. The community simply changed the previous “minimum parking requirements” to “maximum parking allowances.” In the years since this change was made to the ordinance, the standards have been well received by the development community with very few requests for variances that would allow more than the maximum standards.

To review the language and the associated parking standards, readers can view the zoning ordinance through the Town’s website at <http://www.town.exeter.ri.us/Government1.htm>. Parking requirements are located in Article V, Section 5.1 of the ordinance.

## **North Kingstown**

North Kingstown recently instituted sweeping reforms to their parking standards on a Town-wide basis. The Town chose to provide a number of options for site development to achieve both their environmental protection and economic development goals. Strategies employed by the Town include:

- Using parking requirements as both a minimum and a maximum. Most of the new maximum requirements in the ordinance today were the minimum requirements in the old ordinance.
- Allowing up to 100% of required parking to be provided off-site with specific access and maintenance requirements: “...provided that parking is located within 500 feet of the property boundary in a walkable route from one property boundary to another and safe, well lighted pedestrian access can be demonstrated by the applicant.”
- Providing clear guidelines and sample calculations for reductions where parking is being shared.
- Requiring landscaped islands for every 20 parking spaces in single rows.

Readers interested in looking more closely at this suite of strategies can review the ordinance through the Town’s website:

<http://www.northkingstown.org/planningdept/landdevelopment.asp>

The applicable text of the zoning ordinance begins in Article XI, Section 21-270 and Section 21-277.

## **East Providence**

Similar to North Kingstown, East Providence provides a number of regulatory measures to help them more efficiently provide parking and limit impervious cover. Key components of the City’s regulations for parking include:

- Shared parking allowances with requirements for private property owners to demonstrate an adequate legal agreement to multiple agencies in a cooperative review process. The legal agreement must also be recorded in the land evidence records once approved by the City.
- Allowances for permeable pavement to meet environmentally friendly design standards.
- The ability to limit parking to the minimum requirements in environmentally sensitive areas identified in the Comprehensive Plan.
- The ability to hold up to 15% of the required parking area “in reserve” for larger “business/technology” development. These areas are left in a landscaped state until they may be required for documented parking needs. The need for new parking may be determined by observed overspill and is enforced by the City through the use of a legally binding covenant with the property owner.

Readers interested in looking more closely at this suite of strategies can review the ordinance through the City’s website:

<http://www.eastprovidenceri.net/>

The applicable text of the zoning ordinance for shared parking can be found in Article IV, Division 11.

The applicable text for the application of permeable pavers can be found in Article VIII, Section 19-455.

The applicable text for limiting parking to the minimum requirement can be found in Article V, Section 19-284.

The applicable text for parking areas left “in reserve” can be found in Article V, Section 19-370.

## Suggested Resources

- Boston Metropolitan Area Planning Council (MAPC). 2010. *Sustainable Transportation: Parking Toolkit*. <http://mapc.org/resources/parking-toolkit>
- California Metropolitan Transportation Commission (CA MTC). 2010. *Smart Growth / Transportation for Livable Communities*. [http://www.mtc.ca.gov/planning/smart\\_growth/parking\\_study.htm](http://www.mtc.ca.gov/planning/smart_growth/parking_study.htm)
- Center for Watershed Protection (CWP). 1998a. *Better Site Design: A Handbook for Changing Development Rules in Your Community*. Prepared for the Site Planning Roundtable. Elliot City, MD. 172 pp. For purchase/registration access: <http://www.cwp.org/>
- Institute of Transportation Engineers (ITE). 1987. *Parking Generation*, 2nd edition. Washington, D.C. For purchase: <http://www.ite.org/>
- Litman, Todd. 2006. *Parking Management Best Practices*. American Planning Association.
- Litman, Todd. April, 2010. *Parking Management: Strategies, Evaluation and Planning*. 30 pp. Victoria Transport Policy Institute. [http://www.vtppi.org/park\\_man.pdf](http://www.vtppi.org/park_man.pdf)
- Massachusetts Executive Office of Energy and Environmental Affairs (MA EOEEA). 2007. *Massachusetts Smart Growth / Smart Energy Toolkit: Smart Parking*. [http://www.mass.gov/envir/smart\\_growth\\_toolkit/pages/mod-smart-parking.html](http://www.mass.gov/envir/smart_growth_toolkit/pages/mod-smart-parking.html)
- Northwestern Connecticut Council of Governments (NCCOG) and Litchfield Hills Council of Elected Officials. September, 2003. *Model Zoning Regulations for Parking for Northwestern Connecticut*. Connecticut Department of Environmental Protection, Fitzgerald & Halliday Inc. 68 pp. <http://www.fhiplan.com/PDF/NW%20Parking%20Study/NW%20Connecticut%20Parking%20Study%20Phase%202.pdf>
- Rhode Island Department of Environmental Management (RI DEM) and Coastal Resources Management Council (CRMC). December, 2010. *RI Stormwater Design and Installation Standards Manual*. <http://www.dem.ri.gov/programs/benviron/water/permits/ripdes/stwater/t4guide/desman.htm>
- Shoup, Donald. 1999. *The Trouble with Minimum Parking Requirements*. University of California. Transportation Research Part A 33: 539 – 574. <http://shoup.bol.ucla.edu/Trouble.pdf>
- Smith, T. 1984. *Flexible Parking Requirements*. Planning Advisory Service Report No. 377. American Planning Association, Chicago, IL.
- Stein Engineering. January, 1997. *Shared Parking Handbook, Portland Metro: Appendix A, Model Shared Parking Ordinance Provisions*. [http://www.crcog.org/publications/CommDevDocs/TCSP/Ch08\\_Technical\\_Part2\\_Parking.pdf](http://www.crcog.org/publications/CommDevDocs/TCSP/Ch08_Technical_Part2_Parking.pdf)
- Stormwater Managers Research Center (SMRC). 2010. *Better Site Design Fact Sheet: Green Parking*.

Urban Land Institute (ULI). 2005. *Shared Parking 2nd Edition*. 100 pp.

U.S. Environmental Protection Agency (US EPA). January, 2006. *Parking Spaces / Community Places: Finding the Balance through Smart Growth Solutions*. <http://www.epa.gov/smartgrowth/pdf/EPAParkingSpaces06.pdf>

Victoria Transport Policy Institute. January, 2010. *Online TDM [Transportation Demand Management] Encyclopedia*. <http://www.vtpi.org/tdm/index.php>

Wells, C. 1994. *Impervious Surface Reduction Technical Study*. Draft Report. City of Olympia Public Works Department. Washington Department of Ecology, Olympia, WA.

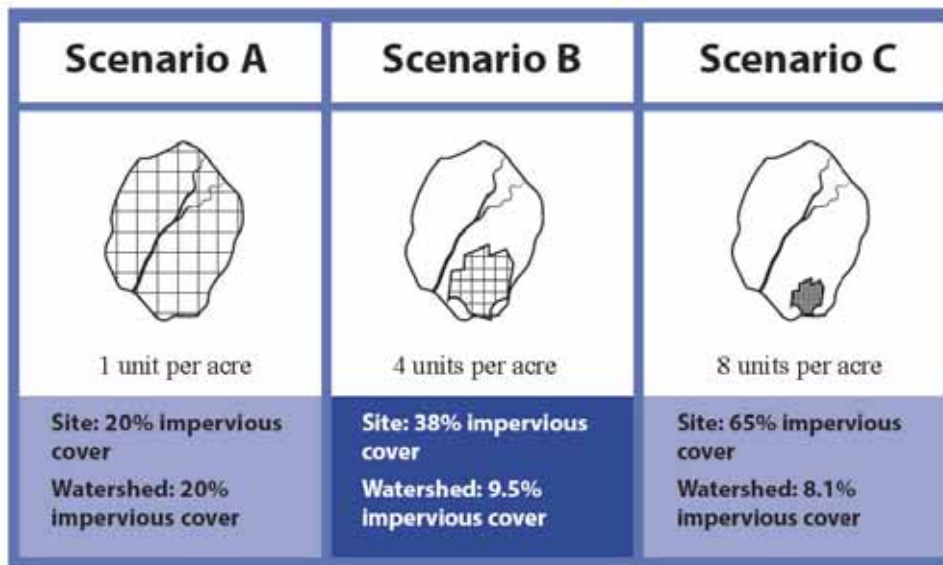
Zimble, Robin. 2005. *Driving Urban Environments: Smart Growth Parking Best Practices*. Maryland Governor's Office of Smart Growth. 46 pp. [http://www.stormwatercenter.net/Assorted%20Fact%20Sheets/Tool4\\_Site\\_Design/GreenParking.htm](http://www.stormwatercenter.net/Assorted%20Fact%20Sheets/Tool4_Site_Design/GreenParking.htm)

## 7.0 LID AND COMPACT DEVELOPMENT

### Current Practice

Since the 1950's many communities have segregated land uses such as residential and commercial into different areas resulting in a more auto dependent and sprawling land use pattern. Moreover, residential development began to use larger lot sizes. These patterns have created unnecessary impervious cover for roads and parking. Generally, as density increases, the amount of impervious cover also increases. The impacts to water quality and aquatic habitat from increased runoff volumes off of impervious surfaces are well documented. However, the overall pattern of development is important in reducing the amount of new impervious cover. As can be seen in Figure 7-1, overall impervious cover for the watershed decreases as site density increases given the same amount of growth. Figure 7-2 shows the existing impervious cover for Rhode Island. Many urban areas are already well above the recommended 10 % threshold of watershed impervious cover (Brabec et al., 2002; CWP, 2002). However, Figure 7-2 also depicts vast areas of Rhode Island that are still well below the 10% threshold. To reduce stormwater runoff impacts in these areas, impervious cover from new growth should be reduced to the greatest extent possible. (For a comprehensive overview of the water quality and habitat impacts of impervious cover for Rhode Island refer to *The Need to Reduce Impervious Cover to Prevent Flooding and Water Quality Impacts*; RI DEM, 2010).

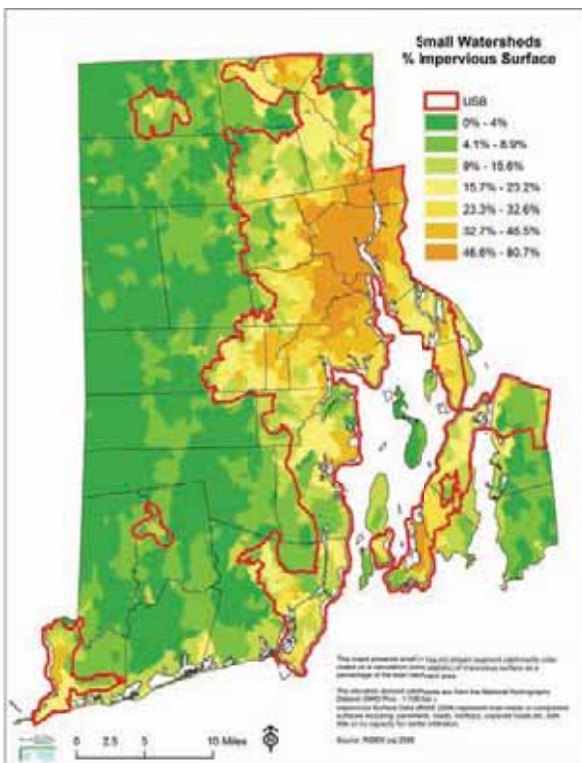
**Figure 7-1 Illustration of Using Higher Density to Reduce Impervious Cover**



This illustration, adapted from the U.S. EPA publication "Protecting Water Resources with Higher Density Development", shows how increasing density at the site level decreases impervious cover for the watershed. (EPA, 2006)



**Figure 7-2 Percent Impervious Cover in the State of Rhode Island with Urban Services Boundary.**



*The area within the Urban Services Boundary is above 25% impervious cover. However the rest of Rhode Island is well below the 10% impervious cover threshold and can support good water quality and habitat. (RI DEM 2010)*

## Objective

Communities should plan for compact growth as called for in Land Use 2025 as the most efficient means to reduce impervious cover on a watershed basis.<sup>1</sup>

## Recommended Practice

Compact mixed use development patterns generate far less stormwater per unit of development than the typical single use suburban model. Furthermore, on the watershed scale, more compact development patterns provide the opportunity to “localize” impacts to the hydrologic balance. Sprawling patterns of development can drop ground water levels on a wide scale, depleting wetlands and stream baseflow as a result. More concentrated nodes of development are easier to manage in a way that is less disruptive to the broader hydrologic balance.

This chapter addresses compact development in the context of mixed use settings, as these areas play an integral role in avoiding and reducing impervious cover impacts on a large scale<sup>2</sup>. **Compact development in the strictly residential context is addressed more directly in Chapter 2, Conservation Development.** With regard to the mixed use setting,

<sup>1</sup> For more details, see the Rhode Island Statewide Planning Program’s State Land Use Policies and Plan, [Land Use 2025](#).

<sup>2</sup> For more details on compact development, see the Rhode Island Statewide Planning Program’s State Land Use Policies and Plan, [Land Use 2025](#).

the individual standards examined include:

- Allowable Uses;
- Discontinue the use of Floor to Area Ratio (FAR);
- Parking Requirements; and
- Setbacks and Building Location.

## Allowable Uses

Perhaps the most common mistake made in today's ordinances is the failure to adequately define "mixed use." It is therefore critical for each community to ensure that appropriate levels of mixed use are clearly defined and incorporated into the Land Use Table of the zoning ordinance. By way of example, the Towns of Warren and North Kingstown define this term as follows:

### Warren (§32-130)

#### *Mixed use, Residential*

A structure used for both residential and commercial purposes, each of which is totally separate from the other. Mixed use residential may be considered for the purpose of allowing residential unit(s) in a non-residential zone, only in a building with commercial use as the sole use on the ground floor. Residential units must be located above the ground floor and contain a minimum of 600 square feet of living space per unit.

### North Kingstown (§21-20)

*Mixed Use* means the inclusion of more than one general type of land use within a single structure or site development as they are grouped in the Land Use Table under Article III. For the purposes of this ordinance, all mixed use projects shall include a residential component that is fully integrated into the site or structure in a way that enables residents to easily access non-residential amenities.

What these two definitions clearly illustrate is that many different aspects of mixed use can and should be addressed in the definition. For example, each definition cited above clearly establishes that residential uses must be a component of development proposals submitted under this use category. The Warren example goes further to discuss other aspects of mixed use within the definition such as which uses are appropriate for different stories and some of the dimensional requirements for residential use.

**Figure 7-3 Mixed Use on Main Street in Warren.**



*By integrating commercial and residential uses, development can grow up instead of out to reduce impervious cover and sprawl. (HW photo)*

### **Discontinue the Use of Floor to Area Ratio (FAR) Standards for Mixed Uses**

FAR measures the amount of floor space developed on a particular parcel relative to the size of that parcel. For example, if a parcel is 80,000 square feet and a building contains 20,000 square feet of floor area, the FAR is 1:4 or 0.25. A close examination of FAR standards reveals more than one disadvantage to this zoning tool. First, as a practical matter, FAR standards are rarely used to limit development on a parcel. This is because other on-site requirements—particularly parking requirements, setbacks, building height limits, and buffers—are more limiting to the development potential than FAR. In other words, once all other requirements are satisfied, it is often physically impossible to exceed the allowable FAR. More important to the discussion of growth centers is the notion that FAR standards may be counter-productive to the goals of redevelopment in these areas.

Second, because growth centers and villages follow traditional neighborhood design patterns, it is important to be flexible with dimensional requirements. The shapes and sizes of lots can make symmetrical development very challenging and in many instances several pre-existing buildings were developed on individual lots without regard for setbacks or other zoning conventions that simply did not exist when these buildings were constructed. As a result, tools such as FAR can prove to be a “blunt instrument” in a built environment that demands a more sophisticated regulatory approach. New urbanist planners often correctly point out that FAR requirements do little to predict the form of buildings, which is a much higher priority in village centers when compared with growth control measures.

### **Parking Requirements**

Perhaps no other zoning tool generates as many challenges for mixed use development as standardized off-street parking requirements. In order to effectively reduce impervious cover and provide for the flexibility needed to redevelop growth centers throughout Rhode Island, it is necessary for communities to revisit their parking requirements within the zoning ordinance. In order to develop favorable parking requirements, more refined analyses need

to be performed beyond referencing standard zoning requirements for individual uses. These analyses should involve calculations based on factors such as the time of peak demands for different uses, the potential mix of uses, the proximity to municipal parking, the population demographics, and the presence of public transportation.

A general rule of thumb for determining optimal parking requirements for mixed use developments is to calculate the highest peak demand over the course of a 24-hour period and design to that level. This is based on the assumption that many uses generate parking requirements throughout different times of the day (e.g. office use parking during the day, and residential use parking during the evening), and therefore can share parking facilities. More detailed analyses are required for more complex mixed use developments that can contain a range of uses with varied overlapping parking requirements (RI DEM, 2005).

**Detailed guidance on how to develop zoning amendments related to mixed use parking is provided in Chapter 6, LID Parking.**

**Figure 7-4 Traditional Village Patterns Require Flexible Approaches to Parking.**



*This photo of the Village of Kingston shows a compact development pattern that is only possible today through innovative parking regulations. (HW photo)*

In addition, communities should consider how the necessary parking will be constructed. The required parking does not necessarily have to result in increased impervious surfaces. Parking can be incorporated into multipurpose buildings either above or below a ground floor of retail establishments, with additional floors containing office or residential uses. This also reduces the land cost chargeable to parking (ITE, 1994; CWP, 1998).

### **Setbacks and Building Location**

The location of buildings on a lot is primarily regulated by the minimum required setbacks from the different property boundaries. For each lot, separate setbacks are usually required for the front yard, the rear yard and the side yards. Beginning with the side yard setbacks, it is relatively easy to see that setback limits in most of our existing village centers did not exist at the time these areas were established. Many buildings share sidewalls or are separated by

slender alleyways no more than 10 feet in width. The result of these close proximities was generally a very walkable streetscape and complementary architecture that created what we all know to be as the “traditional New England village.” As a result, when examining our zoning for these areas, it is generally accepted practice to reduce minimum side yard setbacks to zero.

As a potential exception to this practice for side yards, many communities institute a larger setback for lots where the side yard may abut a residential district. This exception assures neighboring residents that their privacy will be maintained by an adequate separation between their home and a neighboring mixed use structure. Many communities will require that setback to be equal to the highest potential mixed use structure. For example, if buildings within the mixed use district can be up to 40 feet tall, the minimum setback will be equal to that height. At the very least, these setbacks should include enough space to comfortably design a pedestrian sidewalk against the building, a single lane automobile access drive and a substantial vegetated buffer adjacent to the residential use as a screening buffer that can also serve to meet LID stormwater management objectives.

When looking at rear yard setbacks, it is important to maintain the flexibility required for well-designed land development projects. Although it may seem logical to require setbacks in the range of 30 to 50 feet for rear yards in tightly developed areas, it is important to remember that lot configurations in New England villages can be very irregular and rear lot lines can be located virtually flush to the back of existing structures. From the perspective of creating effective zoning ordinance standards for this issue, it may be advisable to explicitly provide waiver powers to local authorities for these special situations. In these cases, a minimum setback of 30 to 50 feet may be required to ensure that loading, trash removal and other similar activities have adequate designated space. But providing local authorities the power to reduce this setback based on unique lot configurations will keep developers out of the variance process, which has much more difficult approval criteria.

Front yard setbacks also have unique considerations in the context of the growth center. At a glance, it is generally accepted that these neighborhoods will benefit from a “zero” setback since most of these walkable streets seem to have buildings flush against the right of way. Reducing front yard setbacks to zero is often seen as the best way to ensure that front yards do not get redeveloped into travel lanes or parking lots. However, it is important to closely examine the actual location of the right of way line as well as to verify ownership of that right of way. For example, front yard setbacks can be a very important way to protect space along the edge of rights of way that are under the jurisdiction of other agencies, such as State agencies. Instead of allowing or requiring a minimum setback of zero, in these situations it may be wise to require a minimum front yard setback of 10 feet. This setback will ensure that adequate space can be dedicated to pedestrian traffic regardless of any changes to roadway configuration within the right of way.

In addition to minimum front yard setbacks, mixed use centers should also require maximum setbacks to discourage the location of buildings in a manner that is not conducive to pedestrian activity. Values between 20 and 40 feet are generally appropriate for these maximum setbacks, with the larger setbacks being more appropriate to areas that will have larger buildings. Regardless of the maximum setback, it is crucial for zoning ordinance language to require that the area within the front yard setback be reserved primarily for pedestrians.



## Perceptions and Realities

Common perceptions that can deter communities from establishing strong ordinance language for mixed use compact development center on density, the impacts that more compact forms of development will have on community character, and issues such as traffic. For many residents, the idea of housing density in excess of four units per acre implies negative impacts to the environment as well as aesthetic impacts that are inconsistent with some suburban or rural landscapes.

The reality of compact development patterns is that they provide a much more efficient use of land that not only allows more people to live in a smaller area, but also allows designers to more effectively mitigate impacts from development. More compact forms of development have a less dispersed, sprawling impact on local hydrology and allow engineers to mitigate impacts in a concentrated fashion. Although many designers claim that compact development makes the use of LID stormwater management techniques more difficult, there are many practices that are appropriate to more urbanized neighborhoods. These practices are covered in significant detail in the RI Stormwater Design and Installation Standards Manual. There are a growing number of versatile practices, such as stormwater planters, small scale landscape infiltration areas, rain gardens that can very effectively manage stormwater quality, and groundwater recharge in very dense developments.

With regard to aesthetic impacts, compact development does not simply imply larger buildings or smaller lots. A well-designed mixed use development is often referred to as “traditional neighborhood design”, as it borrows from many of the historic New England neighborhoods that characterize this region.

### **Figure 7-5 Examples of Compact Development in Rhode Island.**



*The beauty and charm of historic villages such as Wickford (on the left), cannot be easily replicated, but we can learn from the good design features to create new villages. (Historic Wickford Village (HW photo); South County Commons (Dodson Associates)).*

Perception	Reality
Housing density in excess of four units per acre implies negative impacts to the environment.	Compact development patterns provide a much more efficient use of land that not only allows more people to live in a smaller area, but also allows designers to more effectively mitigate impacts from development.
Housing density in excess of four units per acre implies aesthetic impacts that are inconsistent with some suburban or rural landscapes.	With regard to aesthetic impacts, compact development does not simply imply larger buildings or smaller lots. A well-designed mixed use development is often referred to as “traditional neighborhood design”, as it borrows from many of the historic New England neighborhoods that characterize this region.

**Benefits**

**Stormwater Management**

Compact mixed use development is the most efficient means to reduce impervious cover and runoff volume on a per unit basis within a watershed as shown on Figure 7-1. In 2006, the EPA determined that runoff rates were decreased by 74% per house with compact growth compared to a one acre residential subdivision (EPA, 2006). For the same amount of development, compact growth produces less runoff and less impervious cover than low density development.

**Economic and Fiscal**

Compact forms of development also present tremendous opportunities for economic development. In a mixed use setting, a well-designed neighborhood increases the amount of building space that can be developed per unit of land. This is generally the result of lower parking requirements, taller buildings and a more efficient use of infrastructure.

From a fiscal perspective, the design of these neighborhoods reduces the need for automobiles and associated infrastructure. As a result, the amount of pavement required to provide access to local businesses and residences is generally a fraction of what is needed for outlying suburbs and shopping malls and the cost of maintenance drops accordingly. The mix of uses combines housing with revenue-generating activity in a manner that can change development from a tax burden to a tax dollar resource. An op-ed piece appeared in the Narragansett Times in 2006 that provided impressive tax figures for the recently developed South County Commons on land previously zoned for suburban sprawl. The numbers provided in this article showed the sprawl pattern of development costing South Kingstown \$240,000, while the approved mixed use concept will provide positive revenue of over \$620,000.

## Case Studies

There are several communities in Rhode Island that employ innovative standards within their zoning ordinance to encourage compact development patterns in areas identified for future growth. As discussed earlier in this chapter, the critical elements that make a compact development pattern possible include: density allowances, flexible dimensional standards, reduced parking requirements, and allowing mixed use. The following three communities have utilized these standards to help guide growth into a compact model and reduce pressure on natural resources and the transportation network.

### Burrillville Village Planned Development

The Town of Burrillville established regulations for a village planned development (VPD) to allow projects to be fully planned and developed as a comprehensive site. VPDs allow the developer flexibility in terms of the arrangement of buildings while providing the Town with a method of directing higher density growth towards existing village areas. The mix of allowed uses in the VPD shall be compatible within the adjacent village neighborhoods. There are three types of allowed VPDs:

1. *Village residential land development project*: Predominantly residential VPD that also includes public recreational uses (i.e., playgrounds and Town commons) and open space.
2. *Village mixed use land development project*: A mixed use VPD that includes residential, commercial, retail, recreational, open space preservation, and/or municipal uses.
3. *Village industrial land development project*: Predominantly light-industrial VPD that also includes commercial, recreational, governmental, and/or open space preservation uses, the purpose of which is to take advantage of highway access.

Each VPD is designed to encourage shared services and facilities, as well as the use of public sewer (although individual systems may be allowed), public or private water systems, and the creation of a safe, pedestrian-friendly environment. The following key provisions are used to help ensure a compact development pattern and also protect the Town's interests relating to community character:

- Total project density shall be calculated using a minimum lot size per dwelling unit of 12,000 square feet.
- Ensure compatibility between VPDs and existing villages, architectural design features of proposed development must be consistent with existing structures found within Burrillville's two National Historic Districts. Projects must also utilize 'period' lighting/outdoor fixtures, and native landscaping.
- All parking standards are determined in accordance with ITE Trip Generation Guidelines as approved by the Town Planner and Town Engineer, and exempt from the Town's parking requirements in its entirety.
- The Planning Board may authorize zoning incentives of up to 50% of the R-12 zone dimensional requirements for all VPDs, including lot dimensions, internal frontage requirements (if applicable), building setbacks, and buffer zone requirements.
- 20% of all proposed units must be affordable

Readers interested in looking more closely at this suite of strategies can review the ordinance through the Town's website:

[http://www.burrillville.org/Public\\_Documents/BurrillvilleRI\\_Building/index](http://www.burrillville.org/Public_Documents/BurrillvilleRI_Building/index)

The applicable text of the zoning ordinance begins in Section 30-209.

### **Warwick Station Intermodal District**

The City of Warwick has established a zoning district located near its railroad terminal and airport terminal sites that can serve as a higher density, mixed use center. The intent of the Warwick Station Intermodal District is to create and sustain a center of economic activity with a commercial and office core while also allowing residential uses. The boundaries of the district are located along the circular access spine linking the two transportation nodes described above. Regulations require high quality design for pedestrian use, infrastructure improvements that will enable a flow of users between the two transportation nodes, and an appropriate intensity of associated retail, office and hotel uses. Provisions within Warwick's zoning ordinance that make compact development in the area possible are as follows:

- Minimum lot area of 6,000 square feet.
- No minimum requirement for front yard, side yard, or rear yard setback.
- No Floor to Area Ratio (FAR) requirement.
- Maximum structure height of 75 feet.
- Allowances for two-family and multi-family residential buildings.
- Specific parking design requirements within the district, including:
  - o Parking lots shall be located behind, beneath or within commercial buildings.
  - o Whenever possible, surface level parking lots on adjoining commercial lots shall be connected internally to each other to allow for through traffic between and reducing the need for multiple curb cuts.
- Shared parking arrangements are also possible in Warwick to reduce excessive parking.

Readers interested in looking more closely at this suite of strategies can review the ordinance through the City's website:

[http://www.warwickri.gov/index.php?option=com\\_content&view=article&id=787&Itemid=137](http://www.warwickri.gov/index.php?option=com_content&view=article&id=787&Itemid=137)

The applicable text for the Warwick Station Intermodal District begins in Section 301.11.

The applicable text for the Dimensional Regulations begins in Table 2B.

The applicable text for the Parking Requirements begins in Section 701.6A.

### **North Kingstown Post Road District**

North Kingstown has recently established the Post Road District as a mixed use, economic development center. The Town identified this corridor as an ideal fit for compact development due to the availability of infrastructure and potential for improvements through redevelopment. Development in the district will be designed to provide a mix of commercial and residential uses at higher densities; density bonuses are available to encourage environmentally friendly and pedestrian-oriented site design practices and the incorporation of affordable housing into mixed use environments. In addition to adopting regulations for a new zoning district, North Kingstown also conducted comprehensive amendments of several

sections in its ordinance, such as the use table, dimensional table, parking requirements, and new design guidelines to effectively achieve the compact development intended for the district. Key provisions within the Zoning Ordinance include:

- New definition for “mixed use” to better integrate residential and commercial uses within the same building.
- Regulations ensuring that non-residential dominate the ground floors of buildings near Post Road to keep the active uses accessible to pedestrians.
- Restrictions that no new single story buildings will be allowed along Post Road (with specific exemptions for restaurants).
- Inclusion of both minimum and maximum parking standards to reduce amount of required parking and provide more opportunity for economic development.
- Mandatory reduction in parking where shared parking arrangements are possible.
- Density bonuses that can be earned for: 1) environmentally friendly site design, 2) pedestrian-oriented site design, and 3) inclusion of 20% or more affordable housing units.
- Establishment of design guidelines specific to the Post Road District to ensure a high level of building design and municipal review.

Readers interested in looking more closely at this suite of strategies can review the ordinance through the Town’s website:

<http://www.northkingstown.org/planningdept/landdevelopment.asp>

The applicable text for the Post Road District General Requirements begins in Article II, Section 21-94.



## Suggested Resources

- Burchell, Robert W., A. Downs, B. McCann, and S. Mukherji. 2005. *Sprawl Costs: Economic Impacts of Unchecked Development*. Island Press. 208 pp.
- Center for Watershed Protection (CWP). 1998a. *Better Site Design: A Handbook for Changing Development Rules in Your Community*. Prepared for the Site Planning Roundtable. Elliot City, MD. 172 pp. For purchase/registration access: <http://www.cwp.org/>
- Institute of Transportation Engineers (ITE). 1994. *Guidelines for Parking Facility Location and Design*. Washington, D.C. For purchase: <http://www.ite.org/>
- International City/County Management Association (ICMA) and the Smart Growth Network. 2002-2003. *Getting to Smart Growth: 100 Policies for Implementation Vol. I and Vol. II*. [http://www.epa.gov/smartgrowth/getting\\_to\\_sg2.htm#1](http://www.epa.gov/smartgrowth/getting_to_sg2.htm#1)
- Land Use Clinic. 2004. *Strip Corridor Redevelopment: A Guidance Document*. University of Georgia School of Law and College of Environment & Design. 56 pp. <http://www.dca.state.ga.us/development/PlanningQualityGrowth/programs/downloads/StripCorridorRedevt.pdf>
- Local Government Commission Center for Livable Communities (LGCCLC). 2005. *Compact Development for More Livable Communities*. 4 pp. [http://www.lgc.org/freepub/docs/community\\_design/focus/compact\\_development.pdf](http://www.lgc.org/freepub/docs/community_design/focus/compact_development.pdf)
- McCann, Barbara A., R. Ewing. 2003. *Measuring the Health Effects of Sprawl*. *Smart Growth America*. 48 pp. <http://www.smartgrowthamerica.org/report/HealthSprawl8.03.pdf>
- National Association of Local Government Environmental Professionals and the Smart Growth Leadership Institute. 2004. *Smart Growth is Smart Business*. 72 pp. <http://www.resourcesaver.com/file/toolmanager/CustomO93C337F52733.pdf>
- National Oceanic and Atmospheric Administration (NOAA). *Coastal and Waterfront Smart Growth* website. <http://www.coastalsmartgrowth.noaa.gov/welcome.html>
- Rhode Island Department of Environmental Management (RI DEM) and Coastal Resources Management Council (CRMC). December, 2010. *RI Stormwater Design and Installation Standards Manual*. <http://www.dem.ri.gov/programs/benviron/water/permits/ripdes/stwater/t4guide/desman.htm>
- Urban Land Institute (ULI). 2001. *Reinventing America's Suburban Strips*. 32 pp. [http://www.uli.org/ResearchAndPublications/Reports/~/\\_/media/Documents/ResearchAndPublications/Reports/TenPrinciples/Tp\\_SuburbanStrips.ashx](http://www.uli.org/ResearchAndPublications/Reports/~/_/media/Documents/ResearchAndPublications/Reports/TenPrinciples/Tp_SuburbanStrips.ashx),
- U.S. Environmental Protection Agency (US EPA). 2004. *Protecting Water Resources with Smart Growth*. 120 pp. [http://www.epa.gov/dced/pdf/waterresources\\_with\\_sg.pdf](http://www.epa.gov/dced/pdf/waterresources_with_sg.pdf)
- U.S. Environmental Protection Agency (US EPA). 2006. *Protecting Water Resources with Higher Density Development*. 46 pp. [http://www.epa.gov/smartgrowth/pdf/protect\\_water\\_](http://www.epa.gov/smartgrowth/pdf/protect_water_)

higher\_density.pdf

U.S. Environmental Protection Agency (US EPA). December, 2007. *Reducing Stormwater Costs through Low Impact Development (LID) Strategies and Practices*. 37 pp. EPA 841-F-07-006. <http://www.epa.gov/owow/nps/lid/costs07/documents/reducingstormwatercosts.pdf>

U.S. Green Building Council (USGBC). *LEED for Neighborhood Development* website. <http://www.usgbc.org/DisplayPage.aspx?CMSPageID=148>

## 8.0 LID LANDSCAPING

### Current Practice

Most Rhode Island communities provide landscaping requirements and guidelines as part of their Subdivision and Land Development Regulations. However, the requirements for location, spacing, size, and maintenance for street trees, planting and screening can vary significantly from one community to the next. Some communities now reference LID guidelines and require project proponents to demonstrate LID practices that have been used on a project, but lack specificity with respect to soil amendments, preservation of natural vegetation, or utilization of native species. Most landscape provisions fail to document the potential negative impacts of highly fertilized and irrigated turf areas or limit the amount of turf on an applicant's project.

**Figure 8-1 Typical High Impact Residential Landscaping.**



*Too often entire lots are cleared of native trees and shrubs encouraging landowners to establish high-maintenance lawns and plant non-native vegetation. This alters pre-existing hydrology and promotes the use of fertilizers and pesticides. (HW photo)*

### Objective

Communities should require the preservation of as much natural vegetation as possible on a site and encourage low-maintenance native landscaping.

### Recommended Practice

Rhode Island communities should develop and adopt an LID Landscaping section in their Subdivision and Land Development Regulations that specifically addresses the link between a functional landscape and the protection of water resource quality. Landscaping requirements and objectives vary as a function of land use and activity. Residential landscape requirements

will need to be different from commercial, industrial, or institutional requirements. Project location and density also need to be considered; the type of plantings and other landscape features within an urban village, such as planters and plazas, will be different from a rural subdivision. A well-crafted LID landscape regulation should include at least the following elements:

1. Distinct sections and varying goals for differing land uses, densities, and locations;
2. A general section on the potential water quality benefits of LID landscaping as outlined below;
3. General requirements that outline the broad goals of LID landscaping such as minimizing impacts from surface runoff, maintaining natural undisturbed areas, specifying low maintenance/low irrigation plant materials, identifying alternative paving materials that promote infiltration of precipitation and minimize solar reflectance, preserving natural and historic features such as stone walls, lanes, and rock outcrops, and addressing signage and street/courtyard furniture; and
4. Specific design standards for the following:
  - Residential lots of varying size;
  - Open space areas;
  - Recreational areas;
  - Drainage features, such as swales and stormwater management practices;
  - Project entrance features;
  - Buffer areas from “improved” site areas to water resources (e.g., streams, wetlands, coastal shoreline features);
  - Areas disturbed for utility construction;
  - Plazas, parking lots, sidewalks, and building planters;
  - Streets, roads, and cul-de-sacs; and
  - Planting requirements, densities, soil amendments, and requirements for each land use, density and location category.

**Figure 8-2 Examples of Low-Maintenance Vegetation along a Residential Road.**



*By leaving mature trees, this conservation development, built around 2000, minimized changes to pre-existing hydrology and high-impact lawns. Homes are on small lots but native vegetation provides privacy and aesthetic appeal. (J. West)*

Communities should be aware that the RI Stormwater Manual contains provisions for applicants to manage runoff from impervious surfaces by draining small areas over qualified pervious surfaces (QPAs). In general, these QPAs consist of low maintenance vegetation or undisturbed open space. Communities should cross-reference the vegetative targets of their landscaping ordinance with these QPAs (refer to Chapter 4 of the RI Stormwater Manual for more details).

The following provides sample language for communities seeking to implement or update their LID Landscaping Standards. Additional guidance and language for consideration can be found in Appendix B of the RI Stormwater Manual and in the case study examples associated with the North and South Rivers Watershed Association and the Town of North Kingstown.

## LID Landscape Design Standards

### Preamble

Soil and landscaping play an important role in stormwater impacts and treatment results. From a quantity standpoint, the loss of good quality topsoil from many sites during construction results in significant increases in runoff quantities that are often not included in stormwater models used to calculate runoff. High organic content of soils absorbs many pollutants. In fact, peat and compost have been shown to provide considerable pollutant removal and are sometimes used in various treatment strategies.

Landscaping also affects stormwater quality and quantity. Turf areas may have considerably more runoff due to compaction and more pollutant contribution due to the frequently-occurring overuse of fertilizers and pesticides, and excessive irrigation. Alternatively, a tiered landscape containing a canopy (typically large shade trees), understory trees, shrubs and groundcovers provides the most absorption and natural uptake of rainfall. Some turf area should generally be included but typically not an expansive monoculture. A more desirable landscape is diverse and provides wildlife habitat, shade, and beauty along with small scale turf areas.

### 1. General Standards

Landscape areas should include all areas on the site that are not covered by buildings, structures, paving or impervious surface. The selection and location of turf, trees, ground cover (including shrubs, grasses, perennials, and flowerbeds), pedestrian pavement and other landscaping elements shall be used to absorb rainfall, prevent erosion, and meet the functional and visual goals of these standards. Examples of functional and visual goals include: defining spaces, accommodating and directing circulation patterns, and managing hardscape impacts. Where possible, the landscaping design should combine form and function, incorporating drainage features invisibly into the landscape such as through shallow surface drainage areas, and parking lot islands that provide for infiltration of parking lot runoff and sheet flow.

Landscaping should be designed to remain functional and attractive during



all seasons of the year through a thoughtful selection of deciduous, evergreen, flowering and non-flowering plant varieties. Prominent natural or man-made features of the landscape such as mature trees, surface waters, natural rock outcrops, roadways or stonewalls should be retained and incorporated into the landscape plan where possible. The addition of ornamental rocks, fencing and other features new to the landscape are encouraged.

Existing natural vegetation should be retained where possible. Existing trees and shrubs to be retained may be substituted for any compatible required plantings. Lawn areas should be kept to a minimum (see Section 2). Natural re-growth, mulched planting beds, and alternative groundcover plant varieties are preferred. Lawn areas of less than six feet in width, especially adjacent to roads or parking areas, are discouraged since such areas require watering and maintenance, but have little utility and are less likely to thrive.

Native plant species, or plant species that have been naturalized in the area or the surrounding region, should be used. Plant varieties selected should be hardy, drought and salt resistant, and require minimal maintenance. Less hardy, exotic, or higher maintenance plant varieties may be used to supplement minimum landscaping requirements where appropriate, but are not encouraged.

## 2. Recommended Criteria for New Development

- a. For single-family homes and single-family subdivisions, a minimum 25%, and a minimum of 15% for multi-family residential areas, of lot areas must be maintained as undisturbed natural area. If the existing land has been disturbed by prior activities, a natural vegetated buffer and/or undisturbed natural area may be proposed through restoration and revegetation.
- b. Lawn area in residential development shall be limited to the lesser of 20% of the overall lot size or 5,000 square feet.
- c. Tiered landscapes, like natural landscapes, tend to require less maintenance and chemical input once established. These landscapes, including a highly organic soil profile, absorb and cleanse rainfall and runoff so that the quantity and quality are more reflective of a natural hydrology. By using these specifications, water, pesticide, and fertilizer use will be minimized and vegetation will thrive with little but spring and fall cleanup.

## 3. Soil Preparation

- a. Compacted soils restrict root penetration, impede water infiltration, have a higher runoff coefficient, and contain few macropore spaces needed for adequate aeration. Avoiding construction activities on parts of the site will help prevent compaction. In areas where this is not practical, methods to compensate for the compaction shall be employed. Landscape areas should be deep tilled to a depth of at least 12 inches to facilitate deep water penetration and soil oxygenation.

- b. Use of soil amendments is encouraged to improve water drainage, moisture penetration, soil oxygenation, and/or water holding capacity. Soil amendments are organic matter such as compost, mulch, and forestry by-products, but do not include topsoil or any mix with soil as an element. For all newly landscaped areas, including single-family residences, organic matter (three to four cubic yards of organic matter per 1,000 square feet of landscape area) should be incorporated to a depth of four to six inches. Organic content of landscaped soils shall not be less than 6% by volume in the top six inches of the finished topsoil.
- c. For newly landscaped areas where topsoil is limited or nonexistent, or where soil drainage is impeded due to subsurface hardpan or bedrock, a minimum of six inches of sandy loam topsoil should be spread in all planting and turf areas. This shall be in addition to the incorporation of organic matter into the top horizon of the imported soil. Organic content of landscaped soils shall not be less than six percent by volume in the top six inches of the finished topsoil.
- d. Soil analysis of new or renovated turf areas should provide a determination of soil texture, including: percentage of organic matter, an approximated soil infiltration rate, and a measure of pH value.
- e. Existing topsoil should not be removed during construction, but should be stockpiled on site and reused in landscaped areas to promote the retention of native seed stocks and to reduce the spread of invasive species.

#### 4. Mulching

- a. Mulch for areas not used for drainage should be applied regularly to, and maintained in all, planting areas to assist soils in retaining moisture, reducing weed growth, and minimizing erosion.
- b. Mulches include organic materials such as compost and shredded bark and inert organic materials such as decomposed lava rock, cobble, and gravel.
- c. If weed barrier mats are used, the use of inert organic mulches is recommended.
- d. Mulches should be applied to the following depths: three inches over bare soil, and two inches where plant materials will cover.
- e. Mulches for stormwater management areas should be well-aged (6 months) hardwood mulch.

#### 5. Compost

- a. Incorporation of organic matter such as compost improves the structure of the soil. In sandy soils, compost increases the water holding capacity and nutrient retention. The physical and chemical properties of most New England soils can be significantly improved by blending in compost.

- b. Compost shall be well-aged (6-12 months), well-aerated leaf compost (or approved equivalent). Turf grass shall not be utilized for compost since it can have significant levels of pesticides, herbicides, nutrients, etc.
- c. The quantity of compost to be incorporated into a site is determined by the final organic content goal for the soil and is dependent on its existing organic content. Organic content of landscaped soils shall not be less than six percent by volume.

## 6. Parking Lots

- a. Parking lots with more than ten (10) parking spaces shall have formal planting areas designed as bioretention areas, or swales. A minimum of one 2 ½ inch caliper deciduous tree measured at a point six inches above grade shall be provided for each ten parking spaces.

**Figure 8-3 LID Parking Lot Landscaping.**



*Parking lot landscaping at the Moran Shipping building in Providence was installed in local depressions adjacent to the paved areas and is used to treat stormwater runoff. Curb stops are used to keep vehicles away from the landscaping. (HW photo)*

- b. When curbs are utilized around parking lot bioretention or swale areas, they shall have a shallow descending cut that is a minimum of five feet wide to allow drainage to flow from the parking lot into the curbed planting areas for infiltration. See the RI Stormwater Manual for bioretention design criteria.

## 7. Vegetation

- a. Any landscape element that dies, or is otherwise removed, within 3 years after a "Final Acceptance" by the "Approving Authority" shall be promptly replaced with the same, if not similar to, height or texture element as originally intended.
- b. Landscape strips should be mulched or planted with hardy groundcover plant varieties rather than planted as lawn areas. Where landscape strips are

used as part of the drainage system, plantings shall be tolerant of periodic wet conditions, and the landscape strips shall be shallowly sloped to allow infiltration and storage.

**Figure 8-4 Sustainable Landscaping Using Low-Maintenance Ornamentals.**



*Low maintenance ornamentals are an attractive alternative to lawns. (HW photo)*

#### 8. Maintenance

- a. Low maintenance, drought, insect, and disease resistant plant varieties are encouraged so that buffer areas and other required landscaping can be maintained with minimal care and the need for watering, pesticide, or fertilizer use is minimized. For these reasons, native species and species that have long thrived within the region are preferred since such plant species are well adapted to the local environment.
- b. To avoid maintenance problems, soil testing should be conducted prior to planting to ensure that the appropriate plant varieties are selected for various portions of a site.
- c. To avoid maintenance problems and excessive watering, organic matter such as compost or peat should be added to the soil before planting as appropriate to increase the water holding capacity of the soil and to provide nutrients.
- d. Where used, irrigation systems should be installed with moisture meters or other devices designed to avoid unnecessary or excessive watering. Alternatively, irrigation systems should be manually activated.

#### 9. Informal, Re-growth, and Peripheral Landscape Areas

Disturbed areas intended for natural re-growth should be, at a minimum, graded, loamed, and seeded with wildflowers, perennial rye grass, or similar varieties. The planting of native trees, shrubs, and other plant varieties is encouraged. A list of native plant species may be found at the Rhode Island Wild Plant Society website here: [http://www.riwps.org/Going\\_Native\\_-\\_Selecting\\_Non-Invasive\\_Plants.pdf](http://www.riwps.org/Going_Native_-_Selecting_Non-Invasive_Plants.pdf).

The planting of blueberry, rhododendron, winterberry, bayberry, shrub dogwoods, cranberry bush, spicebush, native viburnums, and other hardy shrubs along the edge of cleared woodlands provides for an attractive transition between natural woodland and more formally landscaped portions of a site. Where woodland areas are intended to serve as buffers, such plantings can fill in voids by rapidly reestablishing undergrowth. Perennial flowerbeds are also encouraged.

## 10. Plant Specifications

- a. Trees and shrubs – installation size requirements
  - 1) Minimum size for shade or canopy trees shall be two and one-half inches in diameter measured at a point six inches above grade.
  - 2) Minimum size for small or minor shade trees, ornamental, or flowering fruit trees shall be two inches in diameter measured at a point six inches above grade.
  - 3) Minimum size for evergreen trees shall be six feet in height.
  - 4) Minimum size for shrubs shall be one and one-half feet in height.
  
- b. Planting Specifications
  - 1) Areas intended as planting beds for shrubs or hedges shall be cultivated to a depth of not less than 18 inches. All other planting beds shall be cultivated to a depth of not less than 12 inches.
  - 2) Pits for planting trees or shrubs shall be generally circular in outline with vertical sides. Pits for trees or shrubs shall be deep enough to allow one-eighth of the ball of the roots to be above the existing grade. Pits for trees shall be two times the diameter of the root ball.
  - 3) Cultivated areas shall be covered with not less than a two to three inch deep layer of mulch after planting.
  - 4) All trees and shrubs shall be appropriately pruned after planting, with all broken or damaged branches removed.
  - 5) All plants shall be nursery grown native species. No invasive species are permitted as per the list kept by the Rhode Island Invasive Species Council.
  
- c. Retention of Existing Natural Vegetation
  - 1) The boundary of areas to be cleared should be well defined in the field with tree markings, construction fencing or silt fencing as appropriate to avoid unnecessary cutting or removal.
  - 2) Care should be taken to protect root systems from damage from excavation or compaction.
  - 3) Individual trees, rock formations and other landscape features to be retained should also be clearly marked and bounded in the field.

## Perceptions and Realities

Some misconceptions that have limited the use of LID landscaping are included in the table below.



Perception	Reality
Many landscaping contractors are less familiar with planting strategies.	This is likely true, but more and more communities and organizations are offering training and education on the benefits of native plant materials, so landscaping contractors are becoming more familiar with these installations.
Some property owners prefer a more manicured appearance.	True. LID Landscaping can be designed with a more manicured look where necessary. While it is true that native species are preferred, many cultivars will work just as well and can achieve both environmental benefits as well as aesthetic appeal.
Many property owners desire green lush lawn areas and some prefer large expanses of turf.	True. The switch from a green lush lawn to a natural "xeriscape" will require education and will not be for everyone.
Micro drainage can be difficult to get established, minor erosion gullying prior to stabilization can be a frequent issue.	True. However, careful design and equally important, construction oversight and inspection, can resolve most of these issues. Some minor gullying is to be expected prior to stabilization and will require minor repairs.
Vegetative systems require a long-term commitment to maintenance	True. All stormwater management systems require routine and sometimes non-routine maintenance. Vegetative systems however can reduce the overall maintenance burden by maintaining infiltration capacity even in the midst of significant sediment loading.

**Figure 8-5 Seaside Bioretention Facility.**



Selecting attractive vegetation well-suited to its environment is a critical component of functionality and public acceptance of bioretention systems. (HW Photo)

## Benefits

Landscaping that incorporates LID strategies for stormwater management should serve to meet many of the requirements of the RI Stormwater Manual by absorbing and treating stormwater runoff and pollutants to the greatest extent possible on-site. LID landscaping includes the use of vegetated practices and other features that use soil and landscaping to mimic natural hydrologic features and functions. The high organic content of the soils encourages healthy growth and absorbs and retains rainwater on site as soil moisture, minimizing irrigation needs and runoff quantities.

The following benefits are likely derived from implementing LID landscaping techniques:

- More effective stormwater management and water quality treatment;
- Less demand for irrigation and use of potable water supplies;
- Plant communities that are more resistant to drought and require less fertilizers, pesticides, and herbicides;
- Fostering soil amendments when instituted with landscaping will likely result in (1) increased water conservation, (2) increased nutrient retention, (3) better lawn aesthetics (where used), (4) reduced need for chemical use, (5) improved stormwater retention, and (6) cost-savings to the private property owners and municipalities;
- Plant communities that are less costly to maintain and manage; and
- Site designs that are arguably more aesthetically pleasing.

## Case Studies

### North South Rivers Watershed Association Model Landscaping Ordinance

In 2005, the North and South Rivers Watershed Association (NSRWA) developed a Model Landscaping Ordinance through a grant received from the Massachusetts Environmental Trust (MET). This model ordinance was critically reviewed by Town and State officials, as well as experts in the landscaping and irrigation industry. It was written in such a way to provide a “menu of options” from which Town officials can choose, depending upon their Town-specific needs.

The central purpose of this model ordinance is to provide a mechanism whereby developers will create more sustainable landscapes. The focus of the standards and specifications within the model is on the health of soils, the preservation of natural landscapes, and the development of aesthetically pleasing landscaped areas that are environmentally sound.

<http://www.greenscapes.org/Page-221.html>

The listing of sections within the Model Landscaping Ordinance is as follows:

1. Purpose
2. Definitions
3. Applicability

4. Review and Decision Procedures
5. Exemptions
6. Application Requirements
7. Sustainable Landscape Guidelines
8. Sustainable Landscape Design Standards
  - 8.1 General
  - 8.2 Soil Testing and Preparation
  - 8.3 Tree, Shrub and Plant Selection
  - 8.4 Planting
  - 8.5 Lawn and Turf Grass
9. Sustainable Landscape Design Evaluation Criteria
10. Required Security
11. Monitoring and Inspections
12. Enforcement
13. Severability

### **North Kingstown Landscaping Ordinance**

North Kingstown adopted a new Landscaping Ordinance in the summer of 2010. The ordinance is comprehensive in nature, with specific procedures and LID standards including:

- Detailed landscape plan requirements that allow local officials to review and enforce a detailed planting scheme.
- Provisions for soil protection, tree protection and proper removal of debris from the site.
- Provisions to preserve stone walls and restore slopes.
- Best practices for soil amendements, cultivation, and planting practices.
- Specifications for plant selection including sustainable varieties of turf, shrubs, and trees.
- Design standards for parking lots and screening.
- Minimum canopy requirements.

The applicable sections of the zoning ordinance are 21-276 and 21-277 and can be viewed at: <http://www.northkingstown.org/planningdept/landdevelopment.asp>.

## Suggested Resources

Center for Watershed Protection (CWP). 2005. *Unified Subwatershed and Site Reconnaissance: A User's Manual*. Manual 11. 116 pp.

[http://actrees.org/files/Research/cfw\\_p\\_manual11.pdf](http://actrees.org/files/Research/cfw_p_manual11.pdf)

Detweiler, Amy Jo. 2007. *Xeriscaping in Central and Eastern Oregon*. Oregon State University. 5 pp. [http://www.coic.org/cd/stormwater/docs/Manual/App7A\\_2Xeriscaping.pdf](http://www.coic.org/cd/stormwater/docs/Manual/App7A_2Xeriscaping.pdf)

Connecticut Department of Environmental Protection (CT DEP). 2004. *Connecticut Stormwater Quality Manual: Chapter 5, Source Control Practices and Pollution Prevention*. 18 pp. [http://www.ct.gov/dep/lib/dep/water\\_regulating\\_and\\_discharges/stormwater/manual/Chapter\\_5.pdf](http://www.ct.gov/dep/lib/dep/water_regulating_and_discharges/stormwater/manual/Chapter_5.pdf)

New Hampshire Department of Environmental Services (NH DES). 2010. *Fundamentals of Xeriscaping and Water-Wise Landscape*, WD-WSEB-26-4 4 pp. <http://des.nh.gov/organization/commissioner/pip/factsheets/dwgb/documents/dwgb-26-4.pdf>

Sustainable Sources. 2010. *Xeriscaping* website. <http://xeriscape.sustainablesources.com/>

New York City Department of Environmental Protection (NYC DEP). 2007. *Seven Steps to a Water-Saving Garden*. [http://www.nyc.gov/html/dep/html/ways\\_to\\_save\\_water/xeris.shtml](http://www.nyc.gov/html/dep/html/ways_to_save_water/xeris.shtml)

Rhode Island Department of Environmental Management (RI DEM) and Coastal Resources Management Council (CRMC). December, 2010. *RI Stormwater Design and Installation Standards Manual: Appendix B, Vegetation Guidelines and Planting List*. <http://www.dem.ri.gov/programs/benviron/water/permits/ripdes/stwater/t4guide/desman.htm>

Rhode Island Invasive Species Council. 2001. *Invasives: List*. Rhode Island Natural History Survey. Kingston, RI. <http://www.rinhs.org/ri-invasive-species-resources/invasive-list/>

Irrigation Association, Water Management Committee. April, 2005. *Turf and Landscape Irrigation Best Management Practices*. [http://www.irrigation.org/Resources/Turf\\_Landscape\\_BMPs.aspx](http://www.irrigation.org/Resources/Turf_Landscape_BMPs.aspx)

University of Rhode Island (URI) College of the Environmental and Life Sciences (CELS) Outreach Center and Coastal Resources Management Council (CRMC). 2010. *Rhode Island Coastal Plant Guide*.

<http://www.uri.edu/cels/ceoc/coastalPlants/CoastalPlantGuide.htm>

U.S. Environmental Protection Agency. 2006. *Water Efficient Landscaping: Preventing Pollution and Using Resources Wisely*. [http://www.epa.gov/watersense/docs/water-efficient\\_landscaping\\_508.pdf](http://www.epa.gov/watersense/docs/water-efficient_landscaping_508.pdf)

University of Georgia College of Agricultural and Environmental Sciences Cooperation Extension Service. May, 2007. *Xeriscape: A Guide to Developing a Water-Wise Landscape*. 44 pp. <http://www.marex.uga.edu/advisory/Library/CSCPpdfs/Xeriscape.pdf>

## 9.0 SPECIAL PURPOSE ORDINANCES

This chapter covers four important ordinances that Rhode Island communities can adopt to help protect water resources, environmental quality, and community vitality, including:

- Impervious Cover Ordinance;
- Erosion and Sedimentation Ordinance;
- Review and Inspection Fees; and
- Stormwater Utility Districts.

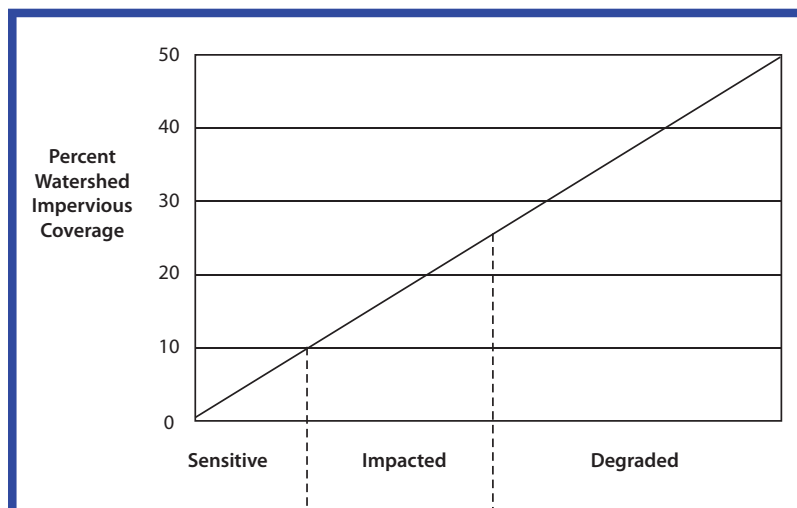
It is important to note that other types of local ordinances, such as On-site Wastewater Management Ordinances and Groundwater Overlay Zoning Ordinances can prevent stormwater pollution. They can identify and control illicit discharges, prevent hazardous materials and improperly treated wastewater effluent from reaching surface waters, and maintain pre-development groundwater recharge.

### IMPERVIOUS COVER ORDINANCE

Impervious cover refers to any man-made surfaces (e.g., asphalt, concrete, and rooftops), along with compacted soil, that water cannot penetrate. Rain and snow that would otherwise soak into the ground turns into stormwater runoff when it comes into contact with impervious surfaces. Stormwater runoff carries dozens of pollutants, such as sediments, nutrients, pathogens, pesticides, hydrocarbons, metals, and deicers, into our surface waters.

The Center for Watershed Protection developed the “Impervious Cover Model” which has been supported by over 200 studies. The Model is based on the average percentages of impervious cover at which stream quality declines, and classifies those impacts into three categories, making management decisions clearer:

**Figure 9-1 Impervious Cover and Impacts to Streams.**





**Sensitive streams** have watersheds that are below a 10% impervious cover. Impacts are generally minor and the water quality and habitat is good to excellent.

**Impacted streams** have water quality and habitat impairments. These are found in watersheds between 10 and 25% impervious cover.

**Degraded streams** have severe water quality and habitat degradation in watersheds with over 25% impervious cover. The impacts are so significant that they are not considered suitable for restoration.

*These ranges are part of a continuum, and there can be variation between individual streams. The model is most reliable when impervious cover exceeds 10%. In watersheds below 10%, water quality and habitat can still be degraded where the forest cover is below 65%, the riparian or vegetated stream buffer is not continuous, and existing pollution sources, such as failed septic systems, are prevalent. (Schueler, 2000)*

## Current Practice

Municipal zoning and subdivision / land development regulations and the patterns of land use they forge are directly responsible for the amount of impervious cover in a watershed. As discussed in Chapter 7, conventional development, over the last several decades most communities have segregated land uses, such as residential and commercial, which has resulted in an auto dependent and sprawling land use pattern. Moreover, conventional residential lot sizes have increased significantly over time. These patterns have created large, unnecessary impervious cover for roads and parking.

The Rhode Island Statewide Planning Program's State Land Use Policies and Plan, *Land Use 2025* is the State's plan for conservation and development in the 21st century. The Plan articulates the State's over-arching goals, objectives, and strategies to guide and coordinate the land use plans and regulations of municipalities and State agencies. The Vision of *Land Use 2025* is that Rhode Island will be a constellation of community centers connected by infrastructure corridors and framed by greenspace. This guide is one tool for accomplishing that vision while protecting water quality and enhancing our natural environment.

## Objective

Communities should plan for compact growth as called for in *Land Use 2025* and establish reasonable impervious cover standards to reduce impervious cover on a community and watershed basis.

## Recommended Practice

Compact mixed use and conservation development should be used to the extent possible since they generate far less stormwater per unit of development than a single family residential house lot in a large lot subdivision, and are the best means to reduce impervious cover. **For more information regarding conservation and compact mixed development refer to chapters 2 and 7, respectively.** *Land Use 2025* should also be referenced. For growth that cannot be accommodated by either compact mixed use or conservation development, communities can establish impervious cover limits.

## Establishing Impervious Cover Limits Through Zoning Ordinances

Over the last ten years, municipal and County governments around the country have started to incorporate limits on impervious cover into their regulations. Most commonly, these have been adopted in specific overlay districts, typically to protect public water supplies or groundwater recharge areas. Increasingly, towns are adopting zoning regulations to limit impervious cover across entire communities. However, it is important to avoid adopting impervious cover limits that would preclude compact mixed use or conservation development.

**Table 9-1: Percentage of Impervious Cover Associated with Various Residential Lot Sizes. (Adapted from RI DEM, 2010)**

Minimum Lot Size	Density in Dwelling Units/Acre	Percent Impervious Cover
10 Acres	0.1	2.4
5 Acres	0.2	5-8
3 Acres	0.33	7-8
2 Acres	0.5	12-16
1 Acre	1	20
0.5 Acre	2	22-31
0.25 Acre	4	38

The Town of Washington, Connecticut has established maximum lot coverage requirements within its zoning regulations to limit impervious cover. The ordinance states:

“In residential districts, the maximum land coverage for all buildings and structures (principal and accessory uses) including paved, impervious, or traveled surfaces shall not exceed:

- a. 15% of the total land area for lots less than two acres,
- b. 0.3 acres for lots between two and three acres (about 12%), and
- c. 10% for lots three acres and larger.”

This recognizes that while smaller lots have a higher percentage of imperviousness, they have lower average imperviousness per dwelling unit.

The ordinance limits imperviousness in business districts to a maximum of 25%. In all cases, lot coverage is defined as:

“the percentage of the lot, which is covered by structures including (but not limited to) buildings, swimming pools, swimming pool equipment, decks, porches, patios, sports courts, chimneys, air conditioning equipment, generators, utility meters, transformers, above ground propane tanks, and most man-made impervious surfaces. Driveways, parking areas, and parking lots are included in the lot coverage calculation whether or not they are paved. Pedestrian walkways are included unless they are made of pervious materials such as gravel, pea stone, or randomly spaced stones set in grass.” (<http://www.washingtonct.org/zoning.pdf>)

On a larger scale, New Castle County and the City of Newark in Delaware have adopted Water Resource Protection Area ordinances that include overall limits on imperviousness (Kaufman & Brant 2000). Functioning as zoning overlay districts, these ordinances limit the amount of impervious cover to a maximum of 10% to 20% in sensitive aquifer, wellhead, recharge and reservoir water resource protection areas. In the reservoir district, new single family development is limited to a maximum impervious cover of 10%, which equates to a gross density of two to three dwellings per acre. Based on this model, Kaufman & Brant proposed watershed zoning for the entire Christina River Basin, covering parts of Maryland, Pennsylvania and Delaware (the latter containing the only drinking water supply streams in Delaware, its only six trout streams, and a growing population of 400,000 people). The zoning ordinance would characterize each portion of the watershed as urban, suburban or open space district, and limit impervious cover to corresponding ranges of 40-55%, 20-35%, and 10-15%.

In an example from North Carolina, Moore County has established impervious cover limits for zoning overlay districts associated with water supply watersheds. ([http://www.co.chatham.nc.us/dept/planning/planning\\_dept/watershed\\_review\\_board/supporting\\_documents/10-70\\_Rule/Planning\\_Board\\_10-70/moore\\_cnty\\_watershed.pdf](http://www.co.chatham.nc.us/dept/planning/planning_dept/watershed_review_board/supporting_documents/10-70_Rule/Planning_Board_10-70/moore_cnty_watershed.pdf))

The County has four different densities within these overlay zones:

- One dwelling unit per 80,000 square feet (sf), or 6% maximum built-upon area;
- One dwelling unit per 40,000 sf, or 12% maximum built-upon area;
- One dwelling unit per 20,000 sf, or 24% maximum built-upon area; and
- One dwelling unit per 14,000 sf, or 36% maximum built-upon area.

The “built-upon area” includes “that portion of a development project that is covered by impervious or partially impervious cover including building, pavement, gravel areas (e.g. roads, parking, lots, paths), recreation facilities (e.g., tennis courts), etc.” The ordinance is interesting in that it ties traditional lot size/zoning density with a cap on imperviousness to the protection of the watershed. Especially within the 40,000 and 80,000 sf zones, developers will have to substantially decrease road widths and other impervious surfaces to remain under the 12% and 6% impervious caps. These per-lot impervious cover ratios must be used with caution since they would preclude a mixed use compact growth development that would significantly decrease imperviousness on a per unit basis and help to reduce overall impervious cover within a watershed.

Since the early 1980’s, the City of Austin, Texas, has been adopting watershed ordinances that are customized for 45 watersheds within the City planning area (City of Austin, 2010). Impervious cover limits range from 15% in sensitive resource areas to up to 30-40% for more urban watersheds. A provision for transfer of impervious cover rights (TICR) allows for increased imperviousness in appropriate areas through transfers from more sensitive locations. The system has withstood numerous legal challenges, and seems to have strong support in an area where natural springs and water courses can disappear quickly when their recharge areas are paved over.

Close attention to impervious cover when formulating planning and management strategies has great potential for helping Rhode Island towns protect low order (small headwater)

streams and ultimately the health of its watersheds. The inclusion of impervious cover in the regulatory process at the municipal level must be used carefully. Towns need to establish a clear link between specific impervious cover thresholds and protection of public health, safety and welfare. Indeed, communities should look at the specific characteristics of their streams and watersheds and adopt thresholds appropriate for their community, ranging from 4% in sensitive cold water trout habitat to 10%. However, on the watershed scale, the 10% threshold can be a valuable benchmark.

As a practical matter, using impervious cover as a surrogate for all of the various water quality impacts allows towns to avoid the cost of tracking dozens of indicators independently. By keeping impervious cover below the threshold where water quality is impacted, towns can avoid having to pursue costly mitigation when it may be too late to provide much benefit.

## Perceptions and Realities

Perception	Reality
Impervious cover limits will restrict compact growth.	Impervious cover limits allow for greater density in appropriate locations. Impervious cover limits can be tailored to the planning needs and resource area values in specific watersheds and districts. Use of LID design techniques will enhance compact growth opportunities.

## Benefits

### Stormwater Benefits

Reducing impervious cover from new development and redevelopment will reduce runoff volume, water quality, and habitat impacts from stormwater runoff.

### Economic Benefits

The reduction of impervious cover can minimize the need for the construction, operation and maintenance of structural BMPs to treat stormwater runoff.

### Benefits to Community Character

Impervious cover limits can encourage compact growth and reduce sprawling development patterns that destroy community character.

## EROSION AND SEDIMENT CONTROL ORDINANCE

There is a profound and measurable link between land alteration and the health of streams, ponds, wetlands, coastal waters, and aquifers. The conversion of native forests and vegetated areas to construct buildings, roads, and parking lots changes surface and groundwater

drainage processes, which can have a negative impact on the local environment and economy. These impacts begin during construction and are influenced by rainfall, soil erosion potential, and the ability to apply and administer proper management practices.

## Current Practice

ESC provisions are included in either Subdivision and Land Development Regulations or Development Plan Review Regulations of a municipal zoning ordinance as part of a preliminary checklist for review by municipal engineering staff or hired engineering consultants, or in some cases can exist as a separate ordinance. Rhode Island has a comprehensive Soil Erosion and Sediment Control Handbook (RI DEM, et al., 1989) that includes a model ordinance for ESC, and requires that effective ESC be mandated by municipal permits as part of the Rhode Island Pollution Discharge Elimination System (RIPDES). ESC is covered by the RI Zoning and Subdivision Acts. These Acts establish the authority for regulation of ESC within municipal zoning ordinances and/or subdivision and land development regulations. In very few cases is there a stand-alone regulation for ESC used within municipalities. There are some cases of single lots that are also susceptible to erosion and sedimentation and are not covered under RIPDES; these are often exempt from local ESC provisions, regardless of the extent of infill and single lot development in the community.

## Objective

Communities should regulate and enforce ESC before, during, and after construction to reduce impacts on the local environment and economy.

## Recommended Practice

Effective ESC is best administered and implemented at the municipal level, where local resources can be aligned with other related ordinances and regulations, and decisions can be made as part of a comprehensive review which considers the sensitivity of the natural environment. Since RI DEM and RI CRMC do not review all projects, a municipal ordinance can set a trigger for regulation that is at least as protective as State and Federal requirements (i.e., disturbance of one acre of land or greater), or more protective, as is deemed appropriate. ESC requirements for small, single lot construction, for example, can be addressed through the adoption of lower disturbance thresholds (e.g., 1,000 sf of land) or through the review during an existing permit application, such as a building permit, which would reduce the additional review burden. In addition, municipal staff may be able to suggest adaptations to practices and procedures that are more familiar to local engineers and contractors and thus, likely to be more effective.

Each RI municipality, under the powers of RI General Law, Title 45, Chapter 46, Sections 1 through 6, and the RI Enabling Acts, should review their existing zoning and subdivision, and land development regulations, and where necessary develop and adopt a separate ESC ordinance for those conditions not covered by their thresholds for existing reviews.



**Figure 9-3 Example of an Erosion and Sediment Control Failure.**



*Erosion and sediment control practices must be selected to meet the specific demands of the area to be managed in order to avoid failures like the one shown here. ([www.muddywaterwatch.org](http://www.muddywaterwatch.org))*

Many RI cities and towns have adopted the original model ordinance from the RI Soil Erosion and Sediment Control Handbook ‘as is’ or with minor variations and have successfully implemented the ordinance over many years. While this model ordinance is a good base for municipalities to refer to, it currently does not meet the minimum requirements of the MS4. The Southern RI Conservation District and URI Cooperative Extension NEMO program made modifications to the model ordinance that are intended to provide additional language allowing municipalities to meet the minimum requirements of Phase II. This document is entitled “Updating Municipal Model Erosion and Sediment Controls to Meet Phase II MS4 Permit Requirements” (August 2009). **A more thorough presentation of this document is covered in Chapter 4, Site Clearing and Grading.**

## Perceptions and Realities

Some misconceptions that have limited the use of an ESC Ordinance are included in the table below.

Perception	Reality
An ESC Ordinance will create another layer of regulation that will drive up the cost of housing and commercial development.	ESC is already mandated by RIPDES and Federal requirements for land disturbance of over one acre, which require among other things, the development of a comprehensive SWPPP. A municipal ordinance can be tailored to suit local needs and customized based on local staff capacity and expertise and sensitivity of local environmental resources.

An ESC Ordinance will be costly to administer at the local level.	An ESC Ordinance can contain provisions for the collection of review and inspection fees as well as the posting of bonds or other sureties to cover the costs of administration.
RI DEM already regulates construction site activities; a local ESC Ordinance is not needed.	RI DEM only regulates construction site activities where activities impact wetlands or other water resources or indirectly through the RIPDES General Permit issues to most RI municipalities for construction activities greater than one acre. A municipal ordinance could provide flexibility for regulating the size and type of construction projects most common in the community.
Extending ESC requirements to small lots will increase local review and inspection burden.	Establishing a small lot general permit during an existing review phase can reduce this burden.
Construction periods are generally short in duration and impacts from construction activity are minor.	While it is true that the construction phase is generally short-term, the impacts can be dramatic. Uncontrolled construction site runoff can have a concentration of sediment two orders of magnitude greater than that from a stabilized post-developed project (Schueler & Lugbill, 1990). Once sediments are deposited in streambeds, ponds, or coastal estuaries, the cost of removal can be hundreds of dollars per cubic yard of material.
ESC measures are expensive to install and maintain.	It is far cheaper to comply with ESC standards and requirements and prevent erosion than to remove sediments from receiving waters and have to restore or replace degraded habitats.

## Benefits

Several benefits are derived by municipal adoption of a local ESC Ordinance, including:

- Protection of water quality and aquatic habitat;
- Economic benefits of higher quality water resources as measured by:
  - Land values,
  - Fisheries,
  - Recreation and tourism,
  - Reduction in maintenance costs,
  - Reduction in restoration costs, and
  - Reduction in pollution related health costs;
- Local control and administration of key program elements;
- A potential source of additional revenue for review and inspections of construction

- site activities; and
- Reduced flooding associated with compromised infrastructure.

**Figure 9-4 Properly Installed Erosion and Sediment Control Practice.**



*This basin shows how sediment from stormwater runoff is being captured before it can reach the forested wetland in the background. (Clemson University)*

## REVIEW AND INSPECTION FEES

### Current Practice

Not all municipalities have the staff capacity to perform the necessary engineering reviews and construction inspections. Some Rhode Island municipalities have developed and adopted a separate ordinance governing the selection and retention of third-party experts to assist in the review and inspection of development proposals. Others have included provisions for review fees within their zoning ordinances and subdivision and land development regulations. Some communities use peer-review professionals, but unless these are authorized by their regulations, they are often hired on an ad-hoc project-by-project basis and sometimes are directly or indirectly retained by the development proponents themselves, creating a perceived, if not direct, conflict of interest where payment can be linked to a favorable peer-review. Where existing regulations have not addressed third-party reviews, a Review and Inspection Fee Ordinance is an important tool that communities may use to retain qualified professionals to review applications and conduct field inspections to ensure that subdivision and commercial/industrial use site plans are prepared in accordance with municipal requirements, and equally important, that projects are constructed in accordance with approved plans. Without this tool, municipalities are severely constrained to conduct assessments of development proposals that may have significant economic, environmental, or social impacts on their communities.

**Figure 9-5 Construction Activity.**



*Construction activities can impact communities during any season and municipalities should require year round inspections. (HW photo)*

## Objective

Communities should enable their boards and departments to thoroughly review the variety of project applications received by adopting provisions for third party reviews within their existing regulations or where applicable, a local Review and Inspection Fee Ordinance.

## Recommended Practice

The goals of preserving natural open space, promoting appropriate residential design, implementing effective ESC, creating aesthetic commercial projects, and reducing environmental impacts from new development projects can be accomplished, in part, through the development and adoption of a local Review and Inspection Fee Ordinance.

As development standards begin to diverge from more routine practices in areas of stormwater management, ESC, general site design, and zoning performance requirements, municipal review authorities and commissions may find it difficult to provide the level of technical scrutiny required for some proposals. In these cases, it is critical that municipal boards be empowered to hire third-party review and inspection services at the expense of the applicant, but with a clear divide between receipt of fees and the performance of an independent technical review and compliance inspections.

Administrative fees can be charged to support third-party reviews as long as the fee relates to the review of the application and is not excessive according to RI Enabling Law. Examples of such fees which can be charged to cover the expenses include, but are not limited to: paying for newspaper publication, certified mail, and staff time as well as provisions for collection of a separate technical review fee to pay for the experts necessary to advise the municipal Boards. In an era when development pressure on sensitive “fringe” lands is increasing, the fee structure outlined here can make a major difference.



## Sample Ordinance Language:

### *Applicability.*

In addition to an Administrative Fee for all Major Subdivisions, Major Land Developments, and proposals requiring Development Plan Review, the Planning Board / Commission shall impose a Project Review and Inspection Fee on those applications which require, in the judgment of the Board / Commission, review by independent consultants due to the size, scale, or complexity of a proposed project, the project's potential impacts, or because the community lacks the necessary capacity or expertise to perform the review and inspection work related to the permit, approval, or compliance. In hiring independent consultants, the Board / Commission may engage engineers, planners, lawyers, landscape architects, architects, licensed site professionals or other appropriate professionals able to assist the Board / Commission and to ensure compliance with all relevant laws, ordinances and regulations. Such assistance may include, but shall not be limited to, analyzing an application, engineering design review, risk assessment, or monitoring or inspecting a project or site for compliance with the Board's / Commission's decisions or regulations, or inspecting a project during construction or implementation. The selection of a consultant and the imposition of fees shall be approved by staff or by the Board / Commission through a public meeting. All requests for proposals (RFPs) for consultant contracts shall be made through a fair and competitive bidding process by formally advertising or soliciting bids from multiple firms.

### *Submittal.*

Project Review and Inspection Fees shall be submitted at the time of the submittal of the application for deposit in an account established by the Municipality [*municipal official officer title*]. Funds shall be retained in an escrow account. Any application filed without this fee shall be deemed incomplete and no review or inspection work shall commence until the fee has been paid in full.

### *Schedule of Project Review and Inspection Fees.*

Upon notification from the Authority that a third-party review shall be performed, the Applicant shall submit \$ \_\_\_\_\_ to the Municipality [*municipal financial officer title*] for deposit into the escrow account. This requirement is in addition to all previous review and inspection fee schedules as they may have appeared in the Zoning Ordinance, the Subdivision and Land Development Regulations, and any listings which may have been compiled from time to time for the benefit of applicants. Where more than one type of application has been submitted for review by the Authority, only the largest of the applicable Project Review and Inspection Fees shall be collected for deposit into the Escrow Account, and not the sum of those fees.

The initial deposit of \$ \_\_\_\_\_ shall serve to begin the review process. Any funds not spent during the review process shall be returned to the Applicant in full. Should the review process require additional funding, these funds shall be provided as outlined below. The Applicant shall have the right to request a detailed expenditure of all funds submitted on behalf of the application.

*Technical review and inspection fees cannot exceed the actual costs of expert assistance. The legal standard requires the fee to be "roughly proportional" to the municipality's costs.*



### *Replenishment.*

When the balance in an Applicant’s Escrow Account falls below twenty-five percent (25%) of the initial Project Review and Inspection Fee, as imposed above, the staff and/or Planning Board / Commission shall consider whether to require a supplemental Project Review and Inspection Fee to cover the cost of the remaining project review and inspection services. If the initial deposit is used, review should cease until replenishment occurs. If there is no replenishment, the project should be denied for failure to submit necessary information lest it be constructively approved.

### *Inspection Phase.*

After the granting of a Development Plan approval or Final Plan approval, the Planning Board / Commission may require a Supplemental Project Review and Inspection Fee for the purpose of ensuring the availability of funds during the inspection phase of the review process.

### *Handling of Project Review and Inspection Fees.*

The Project Review and Inspection Fee is to be deposited into a special account as established by the Municipality [*municipal financial officer title*]. Boards / Commissions are advised to consult with the available municipal staff and Town / City Council, before establishing a fee schedule.

Details regarding specific language on establishing special accounts, reporting, managing excess fees, appeals, and other administrative procedures can be referenced in pages 36-40 of the Appendix to the Rhode Island Urban Design Manual (RI DEM, 2005).

## **Perceptions and Realities**

<b>Perception</b>	<b>Reality</b>
The provision that a municipal Board chooses the expert may be met with resistance by the applicant/developer.	Consultants can be prescreened through a Request for Qualifications (RFQ) process by a municipality. An appeal process of a selection of experts to a municipal Board can be made part of a local ordinance.
Municipal charter constraints and/or custom may require Town / City Council approval of the fee structure.	True. Unless it is part of land development regulations, Town / City Councils may have to review fee structures in accordance with charter requirements. Fees should be reviewed periodically to make sure they cover the cost of review and inspection but are not overly costly to project proponents.

Setting up a Review and Inspection Ordinance is not authorized by Rhode Island General Law

False. RI Enabling Law (R.I.G.L. Section 45 23 58) specifically governs these fees: "Local regulations adopted pursuant to this chapter may provide for reasonable fees, in an amount not to exceed actual costs incurred, to be paid by the applicant for the adequate review and hearing of applications, issuance of permits and the recording of the decisions thereon."

## Benefits

A third-party Review and Inspection Fee Ordinance can offer a municipality several benefits:

- Streamlining the permitting process and ensuring that a high level of design is provided in areas of special community concern;
- The lay persons who volunteer their time to serve on Zoning and Planning Boards are rarely registered professionals in all areas of development review. Civil engineers, landscape architects, architects, historic preservationists, wetlands specialists, and attorneys, among others, bring a necessary expertise to the development review process;
- Municipal boards may use this resource at no expense to the taxpayers of the municipality. The entire cost of technical review and inspections may be passed on to the project proponent; and
- The third-party Review and Inspection Fee Ordinance can be vital to towns without full-time staff assistance. It will also be of assistance to the other towns to help alleviate the burden of professional review and compliance oversight.

**Figure 9-6 Inspection of Bioretention Facility.**



*Third-party inspections should be done to certify that stormwater BMPs were constructed properly. (HW photo)*

## STORMWATER UTILITY DISTRICTS

The demands for more robust and clearly defined stormwater management programs are growing in many communities across Rhode Island, as well as nationwide. Unlike wastewater collection and treatment systems, and drinking water supply systems which have dedicated revenue streams funded by user charges to pay for the operation, maintenance, and administration of these facilities, municipal drainage systems generally do not have a dedicated revenue stream, but the need for operation, maintenance, and administration is no different than these other facilities.

Many municipalities across Rhode Island are struggling to fund the stormwater management program that is required to meet local needs and the requirements of Federal and State water quality programs, such as the RIPDES Program. Regular stormwater management services that communities provide, such as catch basin cleaning and street sweeping, are typically budgeted to some degree into the annual fiscal budget, but typically not at amounts sufficient to meet municipal-wide needs. Programs to map the drainage system and track maintenance and repair for the drainage network are expensive and often get overlooked in the budgeting process when competing with other services such as schools, fire and police. Additional services, such as addressing drainage obstructions, responding to public complaints, and responding to emergencies such as flooding are provided by Departments of Public Works (DPWs) but not accounted for in the stormwater budget. The capacity of DPWs to perform studies, develop designs for drainage and water quality improvements, and educate the public about reducing stormwater pollution is also severely limited by a lack of funding.

### **Figure 9-7 Example of a Neglected Catch Basin.**



*A stormwater utility can help a community raise the funds needed for the proper operation and maintenance of stormwater management systems. (<http://saveourstream.blogspot.com/2010/09/speedway-sand-and-gravel-co-deserves.html>)*

In addition, the way in which stormwater is managed is changing. Rather than piping it as far away as possible, stormwater is being recognized as part of the hydrologic cycle, and therefore integral to the health and stability of rivers and aquifers, particularly in the face of continuing development and land conversion. Many communities are beginning to move toward a more integrated approach to stormwater management and are looking to manage stormwater in a way that improves water quality, reduces flooding and erosion, and improves the maintenance of ecologically sustainable baseflows in streams and rivers.

## Current Practice

Currently, no RI municipality has developed or adopted a Stormwater Utility District, despite having the authority pursuant to enabling legislation enacted in 2002 (See: RI General Law, Chapter 45-61, <http://www.rilin.state.ri.us/Statutes/TITLE45/45-61/INDEX.HTM>). The review, inspection and maintenance of stormwater management facilities require significant resources from municipalities to properly manage a program. Few RI communities have been able to develop and administer truly sustainable stormwater management programs using current funding sources. A Review and Inspection Fee Ordinance to generate revenues will help with some aspects of program administration, but cannot cover long-term inspections and maintenance or repair provisions of a comprehensive municipal stormwater management program. A better solution is for a municipality to adopt and implement a Stormwater Utility District that assesses fees to property owners based on the amount of impervious cover on each lot. Fees generated help to cover administrative program costs and inspection and maintenance of all stormwater structures within the municipality. An example of a successful program is in South Burlington, Vermont (See: <http://www.sburlstormwater.com/>).

## Objective

Communities should adopt a stormwater utility ordinance to help fund the myriad of stormwater services that they currently provide or that may be needed in the future.

## Recommended Practice

Rhode Island communities should consider developing and adopting a Stormwater Management District in accordance with the powers of RI General Law, Title 45, Chapter 45-61. In Rhode Island, as in other parts of the country, the term “stormwater utility” is used to describe what is essentially a fee-based District managed by a division of the municipal government, such as the DPW, to implement a stormwater management program.

Strictly speaking, a stormwater utility would be a separate entity with its own staff, equipment, management structure and financing. For example, the City of Titusville, Florida has established a separate service unit within the City – a stormwater utility – staffed with 14 employees. This new unit or department would be responsible for the planning, operation, construction, and maintenance of the stormwater system. However, more commonly, the term utility is used to describe a fee-based district that is created to support a municipal stormwater management program.



**Figure 9-8 Stormwater Utility Activities.**



*Activities that can be funded through the collection of Stormwater Utility fees include regular inspection, spatial and account data processing, and maintenance activities and equipment. (CWP)*

## **Description and Implementation Strategy**

It is important to define the term “stormwater utility,” as it is used in a number of different ways – often interchangeably when describing the funding mechanism for stormwater management as well as the actual management department.

A distinction should be made between typical stormwater management funding and stormwater utility funding. Typical stormwater management programs draw on a municipality’s general fund for revenue. Funds are then reallocated from the general fund (i.e., capital funding) to a municipal stormwater management program. This type of funding allocation can be unstable as it is provided on a year-to-year basis only, and is therefore subject to competition from other budget needs in the community, such as schools, employee health benefits, fire, police and other variable expenditures. In addition, stormwater managers are not guaranteed these funds, and in some municipalities, financial or political issues stand in the way of managers receiving them. A stormwater utility, alternatively, consists of the special assessment of a long-term funding source for the sole purpose of funding stormwater management operations and maintenance, improvement projects, stormwater planning, project review, regulatory compliance, inspections, and other stormwater management services.

## **Authorizing Language**

Appropriate authorization language is needed to allow for the establishment of a stormwater utility in a municipality. This language can take several different forms. Each ordinance should be written to reflect local municipal conditions and staff capacities and should always have legal review by a municipal solicitor during its drafting. This language is intended to form the framework which should be adapted to municipal code formats and regulation standards.



The first option is to create a section within a Stormwater Management Ordinance or General Municipal Ordinance. This language can be relatively basic, allowing for the creation of a utility, but not specifying the details of administering that program. It would define who is the responsible party or entity for creating the utility, and it would enable that party to develop regulations to define the parameters of the utility. Following is an example of how this language may read ('stormwater utility' can be interchanged with 'stormwater district'):

Stormwater Utility. The *[Stormwater Authority]* may adopt, through the Regulations authorized by this Ordinance, a Stormwater Utility pursuant to Rhode Island General Law Title 45, Chapter 45-61. The *[Stormwater Authority]* shall administer, implement and enforce this Utility. Failure by the *[Stormwater Authority]* to promulgate such a Stormwater Utility through its Regulations or a legal declaration of its invalidity by a court shall not act to suspend or invalidate the effect of this Ordinance."

In the language presented above, the Stormwater Authority may be the DPW, or it may be a newly formed Authority that would also manage the utility.

A second mechanism for authorizing the creation of a stormwater utility is to amend an existing related ordinance to include this language. The language for such an amendment may be as simple as the language provided above.

A third mechanism for authorizing the creation of a stormwater utility is to create a unique ordinance solely for this purpose. Such an ordinance would describe in detail the issues described in this document, including the purpose, jurisdiction, administration, authority, fee or rate schedule, credit system, and enforcement.

In applying any of the three mechanisms listed above, a municipality will want to ensure there are no conflicts with the local Comprehensive Plan.

#### *Jurisdiction of the Stormwater Utility*

The extent of jurisdiction of a stormwater utility should be across the entire municipality. Public roads, public drainage infrastructure, and municipal government serve the entire community, and management of stormwater throughout a municipality will benefit water resources in the public domain. The service area would include all properties that contribute stormwater to the public drainage system, which are essentially all properties that have any impervious area that ultimately drains to any public street or water body in a municipality. For individual properties on which stormwater is controlled on-site and for which owners can show that they do not contribute stormwater to the municipal system, a credit or exemption system can reduce or eliminate the fees.

#### *Possible Funding Structures*

There are a number of options for funding a stormwater utility. In general, most stormwater utilities are based on a rate charged to the public. The differences relate to the type of accounting system (i.e., what account the funds go to), and the assessment of the rate. A community may account for stormwater services for the utility in the general fund, special revenue fund, capital improvement fund, or a separate district. As discussed previously, a general fund includes financial resources used to pay the regular operating and administrative

expenses for a number of departments, particularly funds not properly accounted for by other avenues. A special revenue fund accounts for the earnings of specific revenue sources that are legally restricted to pay for specified purposes. A capital improvement fund accounts for financial resources earmarked for the acquisition or construction of major capital facilities and improvements. Lastly, a Stormwater Management District is a separate accounting and financial reporting mechanism for municipal services for which a fee is charged in exchange for goods or services. This funding system is entirely self-supported through user fees, and is typically the preferred option.

### *Stormwater Management Districts*

Stormwater Management Districts account for the acquisition, operation and maintenance of governmental facilities and services. Stormwater Management Districts are enabled under RI General Law, Title 45, Chapter 45-61. Under district accounting, the revenues and expenditures of the service should be segregated into a separate fund with its own financial statements, rather than co-mingled with the revenues and expenses of all other governmental activities. Establishing a District fund does not create a separate or autonomous entity from the municipal government operation. The municipal department operating the District service continues to fulfill financial and managerial reporting requirements like every other department.

### *Stormwater Budget*

The amount of funding to be raised through the Stormwater District is based on an accounting of all the services to be provided in a given year by that fund. Therefore, the needs and services of the utility must be clearly identified, and then a budget established to reach those goals. The rate assessed to each property will be established to raise the required amount of funding. However, each community has a fee threshold beyond which the public will no longer accept or feel comfortable with the fee. This comfort level should be assessed during the development of the stormwater budget and rate structure so that the fee is acceptable to the public.

### *Rate Structures and Comparison of Alternatives*

First and foremost, it is critical that rates assessed to support a stormwater utility be structured as a service fee and not a tax. The defining characteristic of a stormwater service fee is that the entire amount is used to fund the purposes for which the utility was created. In contrast, taxes are revenues collected by an authorized division of government that can be disbursed for a wide variety of purposes.

A variety of approaches to stormwater fee rates have been employed throughout the country. While no single formula has been identified as the single best option in terms of fairness and ease of implementation, it is generally accepted that flat rates are the most likely kind of revenue stream to raise concerns, and that adjusted rates are more acceptable to customers and most defensible in the event of a legal challenge. However, adjusted rates require collection and interpretation of parcel data, which is labor-intensive and adds to the cost of providing services.

The closer the correlation between service rate and service cost on a parcel-by-parcel basis,

the more legally defensible the fee structure. The percent of the utility's revenue stream from each type of land use should approximately equal the percent of services required to manage stormwater from that land use. Some utilities divide their fees into parts, such as an impervious surface component, a street-related component, and an administrative component, so that customers can see how their money is being spent.

The fee-based approaches described below include a range of options that can be considered; however, the one that has the best combination of simple and fair elements is Option 2 below, in which fees are based on parcel size and impervious cover. The most popular method of billing for a stormwater fee is a rate based on impervious area alone. Other approaches include fee systems based on a combination of gross parcel area and impervious area, gross parcel area and a development factor, and various types of flat fees.

Options for rate-based billing include the following:

1. Flat fees based on land use type (residential versus commercial/industrial) and size.
2. Service fees based on parcel size and impervious cover, measured as Equivalent Residential Units (ERUs). Impervious cover on a site is the driver for calculating the fees.
3. Service fees based on Equivalent Hydraulic Acres (EHAs). Fees are derived based on site factors including impervious cover, pervious cover, water quality impacts and size.
4. Fees based on runoff volume from a prescribed storm event. Fees are based on a site specific calculation of runoff volume from a given storm, such as a two-year storm event.

These four options are described in more detail below.

1. **Flat fees based on land use type and size.** Residential and non-residential properties are categorized by size of parcel or size of impervious area, and a flat rate (monthly or annually) is applied. This rate can be supplemented by a fixed (administrative or other) type of fee to clarify how revenues are spent.
2. **Service fees based on parcel size and impervious cover and measured as "Equivalent Residential Units" or ERUs.** The impervious cover is estimated based on the land use, and is applied to both residential and non-residential land uses. The so-called ERU is identified, usually as the average size of a residential parcel. An average value for impervious cover is used and a specific square footage is assigned based on the imperviousness of the house and the driveway, sidewalk, etc. This value is the baseline from which all service fees are calculated. A rate is set for one ERU, based on the amount of revenue that must be raised to cover the cost of services (ERU values in the communities surveyed ranged from 2,000 to 15,000 sf).

Under the ERU method, residential properties can either be assigned a fee based on a single category for all residential land uses, or more categories of residential parcels can be established, based on size and development intensity, with a set fee for each category. A third option is for the utility to evaluate all residential properties individually for their comparative size and impervious cover (development intensity) relative to the baseline, and calculate a proportionate service fee that may be

different for every property.

3. **Service fees based on Equivalent Hydraulic Acres (EHA).** In this approach, the pervious and impervious areas of a parcel are each multiplied by a runoff factor and added together. A runoff factor accounts for the amount of runoff that is generated from varying types of land surface, such as forest versus lawn versus pavement. The result is multiplied by the utility rate and this total is then multiplied by a water quality factor to calculate the service fee for the parcel. [The volumetric runoff coefficient or the Rational Formula “c” value would work best as the value for the runoff factor.] Since all sites do not generate the same level of pollutant load, a utility may elect to apply a different water quality factor for certain sites, such as sites that typically generate the highest pollutant loads and are considered “Land Uses with Higher Potential Pollutant Loads” under the RI Stormwater Manual. This method requires the utility to calculate the EHA for all properties in a community, which can be a significant administrative burden.
  
4. **Fee based on calculated runoff volume from a prescribed storm event.** Using generally accepted engineering practices, a runoff volume is calculated for each parcel in the service area for storms of varying frequency, such as the 2-year, 10-year, or 25-year storm. The service rate is based on the average annual runoff volume times a fee per unit volume, plus a fixed administrative fee. This method requires the utility to calculate the runoff potential of all properties in the community, which can be a significant administrative burden.

Table 9-2 compares the characteristics of possible fee structures.

**Table 9-2 Comparison of Fee Structures.**

Fee Structure Features	Flat Fee	Equivalent Residential Unit	Equivalent Hydraulic Acres	Runoff Volume
Considers Parcel Size	No	Yes	Yes	Yes
Considers Impervious Area	No	Yes	Yes	Yes
Requires Parcel Categories	Yes	Optional	No	Optional
Standardizes Service Demands	No	Yes	Yes	Yes
Administrative Requirements	Low	Medium-High	High	High
Legally Defensible	Low	High	Unknown	Unknown

The selection of a fee structure and the defensibility of the fee structure are often related to the accuracy of the data used to develop the fee. Most Rhode Island communities currently have reasonably accurate impervious cover data from the RIGIS.

An updated GIS data layer showing parcel delineations will be necessary. This layer must be adjusted to correctly overlay on the orthophotograph of the area so that the parcel lines are accurately shown. The areas in a municipality can be divided by zoning districts or by actual land use categories. The creation of a defensible and accurate fee estimate based on impervious cover will require some updating of available GIS data to accurately identify residential versus non-residential parcels, and then to delineate impervious coverage on individual parcels.

#### *Exemptions or Credits from the Stormwater Fee Program*

A set of standards can be established to determine how a property owner can become exempt from the stormwater fee or earn a credit to reduce their individual fee.

The stormwater authority may create a system of credits for property owners who install and maintain stormwater practices to reduce stormwater runoff from their property or improve the treatment of stormwater runoff from their property (see Table 9-2). Credits are partial to total rebates applied to the total stormwater service bill for a property. For example, credits may be awarded for placement of a permanent conservation easement on a property or installation of stormwater practices that fully manage stormwater on-site. An education credit can also be offered to schools and other institutions that offer a stormwater education program to inform and engage students and members of the public.

Credits are an important component of a utility since they improve the equitability of the application of fees and act as an incentive for private on-site stormwater management improvements. However, a credit system must be simple, and at the same time must support the revenue stream of the utility. Credits for stormwater practices should be tied to a set of stormwater management standards (e.g., the RI Stormwater Manual) with specific measures for quantifying the credit. This will enable ease of design to meet the standard and ease of review by the utility or DPW to evaluate whether the credit has been earned. In the case of conservation restrictions or educational credits, proof of the restriction or the educational program must be submitted. The scale of the credit should reflect the extent to which the volume of runoff is reduced and/or the quality of runoff is improved. A maximum credit amount or minimum fee can be set in order to account for the possible cost associated with future maintenance of any private on-site BMPs that are installed and ultimately have to become part of the utility's responsibility. A credit program needs to be closely coordinated with a municipality's inspection program to ensure on-site measures are maintained in accordance with minimum requirements.



**Table 9-3 Possible Credits and Exemptions for the Stormwater Fee.**

<b>Possible Credits</b>	
Stormwater Practices: Infiltration Basin, Bioretention System, Other	Wetland Restoration
Conservation Easement	Public Education
Reduction in Impervious Cover	
<b>Possible Exemptions</b>	
Undeveloped Property	Municipally-Owned Property
Schools	Public Parks
Churches	Isolated lands that do not drain to a municipality drainage system or regulated Waters of the State

In the case of exemptions, meaning that the property is exempt from the utility’s jurisdiction, the utility needs to decide whether undeveloped properties in the service area are liable for paying service fees, how properties owned by entities other than private landowners or a municipality are rated, and whether a municipality itself is a customer of the stormwater management system. Certain categories of land use are commonly excluded from utility fee rates, such as government property of any type, public parks, railroad rights-of-way, streets and highways, and undeveloped land. However, the relative contribution of each land use type in a municipality should be considered before it is exempted.

It is important to recognize that exemption programs often lead to an increased administrative burden and lost revenue so they should be narrowly defined with clear parameters. In addition, while credits and exemptions may be necessary or perceived to be necessary to provide economic relief and equity, the actual value of a credit may not be high enough to create an incentive for action by most landowners. Only a large site with a large area of impervious cover, such as a commercial or industrial location, may see any substantial economic value in implementing on-site stormwater improvement to abate the fee.

*Stormwater Utility District Implementation Approach*

The key to the success of a stormwater utility or stormwater district program is gaining public support and understanding of the program up-front. Without public education and outreach at the beginning of the process, a fee for stormwater management may be viewed as an unnecessary “rain tax” on the public. The public often assumes that stormwater management is a given. The goal of public education is to teach residents and business owners that while rain is inevitable, the service provided by the municipality to manage that rainfall is just that – a service. Without such a service, a municipality’s public water resources are potentially negatively impacted and individual property owners potentially suffer from flooding. It is also important to convey the idea that there are many additional improvements that can be made to convert from traditional “pipe it away” drainage infrastructure to a more natural system approach that aims to maintain a natural water balance and improve water quality. This educational process is not a simple task, and can take significant time and effort.

Once the public understands the service being provided to them, and the need for funding

this service, they can support the creation of a stormwater program. A stormwater task force or committee may be helpful in ensuring public acceptance. The most effective committee would also include stakeholders, those individuals or representatives of groups that will be affected by the new program. Since a stormwater utility fee can affect all elements of a community, stakeholders may include home, apartment, and condominium owners; commercial and industrial properties; other governments; and schools and other institutional entities.

There are many advantages to this approach to public awareness, as documented by the Florida Stormwater Association (2003):

- Information can be distributed to a smaller group, and the message provided can be tested on this group before distribution to the public at large;
- If the group is made up of stakeholder members, then municipal managers can receive feedback on public opinion quickly;
- Once consensus has been reached with the committee, the committee members themselves become advocates and maybe champions of the program; and
- The committee/task-force process offers knowledgeable public input that can be incorporated into the overall plan. Such input reflects positively for media and public discussions.

A Stormwater Committee or a DPW, or both jointly, may take the lead in the development of an ordinance or ordinance amendment to enable the program. This should be a public process that involves various opportunities for input from citizens. Once the language is drafted, the major task of adopting the ordinance begins. Strong public education efforts up-front can streamline adoption of the ordinance. The major steps in moving the stormwater utility from concept to reality include:

- 1. Conduct Public Outreach and Education:** Media campaigns highlighting stormwater improvements being planned or recently performed, improvements in water resource conditions, or the requirements of the RIPDES permit can all help the public to understand the “service” being provided by a DPW. Include statements, information and data that describe stormwater management as no different than wastewater or water supply management in terms of services. Workshops with business owners in the commercial area of a community, or with residents in areas experiencing erosion, non-point source pollution impacts, low streamflow or flooding can be effective in teaching the benefits of LID techniques in managing stormwater. Mailers and fliers can be distributed with water, sewer, electric, or tax bills. These fliers can be used to highlight the services provided by a DPW to keep storm drains clear of debris, point out maintenance activities that the public may see, such as catch basin cleaning, or highlight stormwater projects that are taking place. For example, any projects being undertaken with grant money can be touted. It is also helpful to link these mailers to an event, such as a workshop, a watershed activity day, public kayak outing, or an information booth at a summer fair. Another audience for stormwater outreach and education is children, who can be reached through school activities or day camps.

Local environmental and outdoor organizations can also be engaged. After all, the goal of better stormwater management is to improve the condition of water resources and the environment, and protect public safety.

- 2. Elicit Public Support:** A series of public meetings addressing stormwater management can be a helpful way to publicize the need for additional funding. These meetings could be held in a large central location, or a series of meetings could be held at various venues around the community to try to attract a variety of constituents, from business owners to residents in certain individual neighborhoods. These meetings should provide a background about stormwater management, describe ongoing activities and permit requirements of a municipality related to stormwater management, and introduce the idea of a funding mechanism.
- 3. Create Authorizing Language:** A draft of the authorizing language should be prepared during this education and outreach process. This effort will probably be led by a DPW or a Stormwater Committee, but should include an open process that allows for public input and participation. If the authorizing language is a relatively modest amendment allowing for the creation of a stormwater utility or fund, this step can be simpler. However, if a municipality chooses to create a full ordinance describing the parameters of the stormwater utility, this step will require a more focused effort by a DPW and/or a Stormwater Committee.
- 4. Adopt Ordinance:** The final step in authorizing the creation of a stormwater utility or district is the adoption of the authorizing language. As noted earlier, the authorizing language can be in the form of a relatively modest authorizing amendment to an ordinance or a more comprehensive ordinance defining all the key parameters of the program. This ordinance or ordinance amendment will need to be introduced for a vote by the legislative branch of municipal government.
- 5. Create Regulations:** This step will be necessary if the authorizing language that is adopted is simple and requires the creation of regulations to further define the stormwater utility or district. Regulations can be created by the stormwater authority that is established by the authorizing language. This may be a DPW, a Stormwater Committee or some other municipal entity.
- 6. Ongoing Public Education:** As the program starts up and begins to collect fees and pay for projects and services, the progress of the program should be highlighted to the public. Progress that can be documented through water quality improvements, numbers of catch basins cleaned or replaced with deep sumps, replacements of undersized culverts, or restoration miles along a stream, provides an excellent opportunity to build support for the project. As new watershed or stormwater issues arise, the utility or fund staff should continue to communicate with the public and discuss how these issues can be addressed and how improvements will be made.

### *Summary of Recommendations for a Stormwater Utility*

The following key recommendations seem to be the most appropriate for RI municipalities in adopting a stormwater utility special use ordinance.

**Management of Stormwater Program:** It is recommended that the technical aspects of the stormwater program be managed by a DPW. Over time, if the programs grow, and depending on current existing utilities within a community, it may make sense to consider combining other utilities with a DPW under one umbrella. It may also make sense for smaller population communities to investigate the development of a regional utility that can more efficiently administer a multi-municipality program.

**Provide a Realistic Set of Stormwater Services to Start:** Most communities are concerned about a relatively limited number of issues. Implementing a stormwater district based on a budget and fee structure that supports realistic goals will provide a simpler budget and smaller stormwater fees as the program gets up and running. This allows a municipality to introduce residents to the idea of a stormwater fee with a fee that is inexpensive and targeted. This being said, municipalities must understand their obligations under RIPDES and in watersheds that may contain Total Maximum Daily Load (TMDL) requirements, so program elements should be well thought-out. It is also recommended that a stormwater utility provide for a stormwater coordinator to manage the program and provide engineering services, some additional maintenance funding, and a small budget for public education to let people know about the program. At the beginning of a program, existing stormwater services such as maintenance could continue to be funded out of other funds if a community is concerned about high initial fees.

**Credits and Exemptions:** A very simple credit system targeted to large commercial and industrial users is recommended. Exemptions should be clearly defined.

**Authorizing Language:** It is recommended to include authorizing language within a new or amended ordinance. The ordinance must clearly identify a stormwater authority responsible for managing the stormwater utility.

**Simple Fee Structure Based on ERUs:** A fee structure based on ERUs is a proven method for connecting each individual lot to the stormwater management service being provided by a municipality. It is recommended that a simple rate structure for residential units that either uses one ERU for all residential units, or includes a tiered structure that differentiates between single, two, and three-family residences.

## Perceptions and Realities

Perception	Reality
Stormwater utilities are not legal in Rhode Island.	False. A stormwater management utility may be created as a Stormwater Management District in accordance with the powers of RI General Law, Title 45, Chapter 45-61.
Stormwater utilities are just another name for a stormwater tax.	False. A stormwater utility is a fee for service based program where only specific charges are applied and money is spent on prescribed services, such as stormwater facility and drainage system maintenance, inspections, and plan reviews.

<p>Stormwater utilities are expensive and not needed. After all, they have never been needed in the past.</p>	<p>False. Fee programs as small as \$25 to \$50 per year for a typical household can fund a robust municipal program. Utilities that fund maintenance of facilities, improvements to water quality, and community character contribute to higher property values and enhanced quality of life.</p>
---	--

## Benefits

Municipalities are finding a need for a dedicated, long-term funding source to be able to provide a range of stormwater management services. Benefits include being able to provide the following representative activities:

1. Compliance with the RIPDES Stormwater Permit, which includes six minimum measures:
  - a) Public education and outreach,
  - b) Public participation,
  - c) Illicit discharge detection and elimination,
  - d) Construction site runoff control,
  - e) Post-construction runoff-control, and
  - f) Pollution prevention/good housekeeping;
2. Maintenance of current stormwater infrastructure, which may include:
  - a) Maintenance of public facilities,
  - b) Maintenance of new private stormwater management facilities under easement agreements, and
  - c) Maintenance of private stormwater management systems in developments that are increasingly permitted through local ordinances and regulations;
3. Inspections of projects, both during construction and post-construction.
4. Continued assessment and engineering design to improve specific water resources within a municipality.
5. Retrofits of the existing stormwater management system with current BMPs to replace/upgrade undersized or failing facilities, as well as to enhance pollutant removal performance to meet TMDL requirements.
6. Implementation of new BMPs and LID for stormwater management in new development projects.
7. Additional stormwater management planning program areas:
  - a) Upgrade of geographic information systems (GIS; e.g., creating new data layers delineating stormwater infrastructure);
  - b) Investigation of infrastructure components (e.g., determining exactly where pipes lead and where and how catch basins are connected). This is particularly useful for the control of reported spills; and
  - c) Development of a more detailed maintenance schedule (e.g., accounting for variations in system failure when scheduling cleanouts).



**Figure 9-9 Stormwater Facility Requiring Regular Inspection.**



*Stormwater treatment facilities will need regular inspection and maintenance to function properly. (HW photo)*

## Case Studies

### Impervious Cover Ordinances

Case studies for Impervious Cover Ordinances are discussed in the body of this Chapter under *Establishing Impervious Cover Limits Through Zoning Ordinances* on page 122.

### Erosion and Sedimentation Ordinances

**Erosion and Sediment Control case studies are discussed in Chapter 4.0, Site Clearing and Grading Standards.**

### Review and Inspection Fees

The use of review and inspection fees is perhaps the single most important tool a community can use for protecting natural resources and promoting appropriate residential and commercial development. An administrative fee is collected to pay for newspaper publication, certified mail, and staff time. In addition, a technical review fee is separately collected to pay for the experts necessary to advise the Zoning and Planning Boards. The South County Watersheds Technical Planning Assistance Project outlines several elements and schedules that every municipality should consider incorporating into local codes and policies. The Towns of Exeter, North Kingstown, Smithfield, and Gloucester are just a few examples of communities that have adopted the review and inspection fee ordinance.

### Stormwater Utility

While no RI municipality has adopted a Stormwater Utility District as a funding mechanism, there are well over 800 utilities nationwide (EPA, 2009). Recently, however, the concept

of adopting a utility has gained more attention as small MS4s respond to increased costs associated with federal National Pollutant Discharge Elimination System (NPDES) Phase II program requirements.

#### *Town of Reading, Stormwater Enterprise Fund*

In 2006 the Town of Reading, Massachusetts established a stormwater utility – termed the Stormwater Enterprise Fund (SWEF) – to provide a dedicated source of funding to support additional stormwater responsibilities mandated under NPDES Phase II and to address long-standing water quality and infrastructure repair issues. The Town has a population of approximately 24,000 (2000 Census) and is just under ten square miles in size. Stormwater management falls under the Department of Public Works (less than ten employees), though other Town divisions are involved in stormwater-related activities.

Prior to establishment of the SWEF, all stormwater-related work was funded through the Town's general fund and was primarily limited to catch basin cleaning, street sweeping, and ditch maintenance for an estimated annual budget of \$165,000. Total estimated annual program costs for implementing additional NPDES Phase II requirements (e.g., illicit discharge, drainage structure mapping, pollution prevention, public involvement and education), as well as completing a backlog of drainage repairs, BMP maintenance, and stream improvement projects, was estimated to be approximately \$540,000/yr as follows: \$203,000 for personnel; \$285,000 for capital costs for drainage-related equipment and projects; and \$52,000 for contractual services (e.g., street sweeping and consulting services).

To bridge this \$375,000 shortfall, an advisory group comprised of members representing selectmen, planning board, conservation commission, finance, general public, and water and sewer utility recommended the establishment of a stormwater utility. After three years of work to develop a legally defensible and equitable rate structure, the Town adopted the SWEF that is now administered by DPW containing the following elements:

*Rate Structure* – extensive GIS analysis was used to determine the average impervious cover (i.e., rooftops, driveways, and parking areas) on single and two-family residential properties, which was calculated as 2,552 sf (defined as one ERU). One ERU is charged a rate of \$39.84 annually, which was determined based on the required annual program budget and the optimal distribution of fees across all Town parcels. Single and two-family residences are billed the flat rate of \$39.84/yr, while all other properties (i.e., multi-family, commercial/ industrial, municipal, and institutional) are assessed an annual stormwater fee based on the total amount of impervious cover on the lot at a rate of \$39.84 per 2,552 sf of impervious surface. For example, the fee for a commercial property with 25,000 sf of impervious cover is:

$$(25,000 \text{ sf} / 2,552 \text{ sf}) * \$39.84 / \text{yr} = \$390 / \text{yr}$$

**Figure 9-10 Impervious Cover Analysis Used to Determine Stormwater Utility Rates.**



Using high resolution aerial photography, the Town measured impervious areas for each tax parcel. The average imperviousness for single and two-family residential lots was calculated and set as the ERU of 2,225 sf (Delany et al, 2009).

**Billing** – billing for the stormwater fee appears as a separate charge on the quarterly water and sewer bills. Properties that did not previously receive a water and sewer bill (e.g., parking lots) will now receive a bill assessing only the stormwater fee.

**Exemptions and Abatements** – the only exemptions from the utility fee are undeveloped properties. Municipal properties, such as schools, and properties owned by religious or registered non-profit organizations are not exempt from the stormwater utility since they generate stormwater and are also subject to other utility fees (i.e., water, sewer, electric). Property owners receive a 10% discount if the bill is paid early. Credits of up to 50% of the assessed fee are available to residential properties that install infiltration systems or other means to reduce runoff (rain barrels excluded), as well as to other properties that install and maintain state-of-the-art stormwater treatment and infiltration systems. Typical devices that qualify for abatement include dry wells, infiltration chambers, and detention ponds.

**Public Education** – an extensive effort was implemented up-front to notify the public during development of the utility via billing inserts, newspaper articles, and presentations at meetings. Program operating budgets, abatement application forms, stormwater facts and frequently asked questions are posted on-line at [www.readingma.gov](http://www.readingma.gov) for increased transparency.

## Suggested Resources

### **Stormwater Utilities and Financing**

Charles River Watershed Association (CRWA). 2007. *Assessment of Stormwater Financing Mechanisms in New England*. Massachusetts Coastal Zone Management. 70 pp. <http://www.crwa.org/projects/stormwater/Municipal%20SFM%20Case%20Studies%20Repo.pdf>

Delany, Joe, K. Honetschlager, and T. McIntire. 2009. *Structuring a Stormwater Utility*. Town of Reading, MA. [www.salemsound.org/ReadingStormwaterUtility.pdf](http://www.salemsound.org/ReadingStormwaterUtility.pdf)

Mulcahy, Laura Anne. May, 2008. *The Effectiveness of Stormwater Utilities in Mitigating Stormwater Runoff in the United States*. Masters Thesis. Brown University. 115 pp. <http://envstudies.brown.edu/theses/archive20072008/lauramulcahythesis.pdf>

National Association of Flood and Stormwater Management Agencies (NAFSMA). January, 2006. *Guidance for Municipal Stormwater Funding*. US EPA. National. 140 pp. <http://www.nafsma.org/Guidance%20Manual%20Version%202X.pdf>

New England Environmental Finance Center. May, 2005. *Stormwater Utility Fees*. <http://efc.muskie.usm.maine.edu/docs/StormwaterUtilityFeeReport.pdf>

Pioneer Valley Planning Commission. 1998. *How to Create a Stormwater Utility*. Massachusetts Department of Environmental Protection. [http://www.pvpc.org/web-content/docs/landuse/storm\\_util.pdf](http://www.pvpc.org/web-content/docs/landuse/storm_util.pdf)

Strand Associates . February, 2007. *Stormwater Utility Study*. [http://www.lancasterwisconsin.com/pdf/stormwater/stormwater\\_utility\\_study.pdf](http://www.lancasterwisconsin.com/pdf/stormwater/stormwater_utility_study.pdf)

U.S. Environmental Protection Agency (US EPA). April 2009. *Funding Stormwater Programs Factsheet*. 6 pp. [www.epa.gov/region1/npdes/stormwater/assets/pdfs/FundingStormwater.pdf](http://www.epa.gov/region1/npdes/stormwater/assets/pdfs/FundingStormwater.pdf)

### **Erosion and Sediment Control**

Rhode Island Department of Environmental Management (RI DEM), USDA Soil Conservation Service, and Rhode Island State Conservation Committee. 1989. *Rhode Island Soil Erosion and Sediment Control Handbook*. [http://www.dot.ri.gov/documents/enviro/stormwater/Soil\\_Erosion\\_Sediment\\_Control\\_Handbook.pdf](http://www.dot.ri.gov/documents/enviro/stormwater/Soil_Erosion_Sediment_Control_Handbook.pdf)

Rhode Island Department of Environmental Management (RI DEM). May, 2001. *South County Design Manual*. <http://www.dem.ri.gov/programs/bpoladm/suswshed/desmanul/toc.html>

Southern Rhode Island Conservation District and URI Cooperative Extension NEMO Program. August, 2009. *Updating Municipal Model Erosion and Sediment Controls to Meet Phase II MS4 Permit Requirements*. 12 pp. <http://www.uri.edu/ce/wq/NEMO/Workshops-Support/PDFs/ConstructionSiteRunoff.Aug2009/Aug25%202009%20RIGLannotated.pdf>

## **Impacts of Impervious Cover on Watershed Quality**

- Brabec, Elizabeth, St. Schulte, and P. L. Richards. 2002. *Impervious Surfaces and Water Quality: A Review of Current Literature and Its Implications for Watershed Planning*. *Journal of Planning Literature*, Vol 16, No. 4.
- Carson, Hartwell, B. Eaker, P. Gibson, and M. Randall. 2005. *Human Health Impacts from Stormwater Runoff*. River Link, Land-of-Sky Regional Council, Division of Water Quality. [www.seris.info/RiverLink/techinfo.shtml](http://www.seris.info/RiverLink/techinfo.shtml)
- Center for Watershed Protection (CWP). 2002. *Is Impervious Cover Still Important? Runoff Rundown*. Ellicott City, MD. <http://www.cwp.org/newsroom/runoff-rundown.html>
- City of Austin. 2010. *Watershed Protection Development Review: Watershed Ordinances* website. <http://www.ci.austin.tx.us/watershed/ordinances.htm>
- Clausen, John C., G. Warner, D. Civco, and M. Hood, 2003. *Final Report: NEMO Impervious Surface Research*. Dept. of Natural Resources Management & Engineering, College of Agriculture and Natural Resources, The University of Connecticut. Storrs, CT. 18 pp. [http://nemo.uconn.edu/tools/impervious\\_surfaces/pdfs/Clausen\\_etal\\_2003.pdf](http://nemo.uconn.edu/tools/impervious_surfaces/pdfs/Clausen_etal_2003.pdf)
- Hurd, James D. and D. L. Civco, 2004. *Surface Water Quality and Impervious Surface Quantity: a Preliminary Study*. Center for Land Use Education and Research, Department of Natural Resources Management & Engineering, College of Agriculture and Natural Resources, The University of Connecticut, Storrs, CT. 61 pp. [http://nemo.uconn.edu/tools/impervious\\_surfaces/pdfs/Hurd\\_Civco\\_2004b.pdf](http://nemo.uconn.edu/tools/impervious_surfaces/pdfs/Hurd_Civco_2004b.pdf)
- Paul, Michael., J. Meyer. 2001. *Streams in the Urban Landscape*. Institute of Ecology, University of Georgia. *Annual Review of Ecology and Systematics*. Vol. 32: 333-365. , Athens, Georgia. <http://arjournals.annualreviews.org/doi/abs/10.1146/annurev.ecolsys.32.081501.114040>
- RI Department of Environmental Management (RI DEM). May, 2010. *The Need to Reduce Impervious Cover to Prevent Flooding and Protect Water Quality*. <http://www.dem.ri.gov/programs/bpoladm/suswshed/pubs.htm>
- RI Department of Environmental Management (RI DEM). January, 2005. *The Urban Environmental Design Manual: Appendix – Development Criteria*. <http://www.dem.ri.gov/programs/bpoladm/suswshed/pdfs/devcriap.pdf>
- Schueler, Thomas. 2000. *The Importance of Imperviousness*. The Practice of Watershed Protection. Center for Watershed Protection. Ellicott City, MD. For purchase/registration access: <http://www.cwp.org/>
- Wright, Tiffany, J. Tomlinson, T. Schueler, K. Cappiella, A. Kitchell, and D. Hirschman. 2006. *Direct and Indirect Impacts of Urbanization on Wetland Quality: Wetlands & Watersheds Article #1*. Center for Watershed Protection, Ellicott City, MD. For purchase/registration access: <http://www.cwp.org/>



## **Zoning and Regulatory Tools for Impervious Cover**

- Gibbons, Jim. 1998. *Addressing Imperviousness in Plans, Site Design and Land Use Regulations*. Nonpoint Education for Municipal Officials Technical Paper Number 1. University of Connecticut Cooperative Extension, Haddam, Ct. [www.nemo.uconn.edu](http://www.nemo.uconn.edu).
- Kauffman, Gerald J. and T. Brant. 2000. *The Role of Impervious Cover as a Watershed-based Zoning Tool to Protect water Quality in the Christina River Basin of Delaware, Pennsylvania, and Maryland*. University of Delaware, Institute for Public Administration, Water Resources Agency, Newark, DE. [http://www.wr.udel.edu/publications/ImperviousCover\\_WatershedBasedZoningTool.pdf](http://www.wr.udel.edu/publications/ImperviousCover_WatershedBasedZoningTool.pdf).
- Kauffman, Gerald J, M. B. Corrozi, and K. J. Vonck. 2002. *Imperviousness: A Performance Measure of a Delaware Water Resource Protection Area Ordinance*. University of Delaware, Newark, DE. 17 pp. [http://www.wr.udel.edu/publications/Imperviousness\\_DEWRPAOrdinance.pdf](http://www.wr.udel.edu/publications/Imperviousness_DEWRPAOrdinance.pdf)
- Richards, Lynn, G. Anderson and M. K. Santore. 2003. *Protecting Water Resources with Higher Density Developments*. Proceedings of the 13th Biennial Coastal Zone Conference, Baltimore, MD. [http://www.epa.gov/piedpage/pdf/protect\\_water\\_higher\\_density.pdf](http://www.epa.gov/piedpage/pdf/protect_water_higher_density.pdf)
- Russell, Joel. 2004. *Overlay Zoning to Protect Surface Waters*. Planning Commissioners Journal, Number 54. <http://www.ci.davidson.nc.us/DocumentView.aspx?DID=895>
- Stone, Brian, Jr. 2004. *Paving Over Paradise: How Land Use Regulations Promote Residential Imperviousness*. Landscape and Urban Planning 69 (2004) 101-113. <http://www.urbanclimate.gatech.edu/pubs/Paving%20Over%20Paradise.pdf>



## Appendix A Ordinance Checklist for LID Stormwater Site Planning and Design Techniques

The Ordinance Checklist for LID allows a community to determine what specific LID site planning and design techniques they have adopted or may need to adopt to avoid, reduce and manage stormwater impacts from new development and redevelopment. The checklist is organized by three broad goals and ten objectives that are from the *Rhode Island Stormwater Design and Installation Standards Manual*. Below each objective are examples of LID site planning and design techniques that can be incorporated into existing community ordinances to achieve the objective. Communities are encouraged to adopt any alternative techniques not listed below that can still meet the desired objectives. Moreover, not all site planning and design techniques are applicable to every community. Before making any changes to local land use regulations, communities should involve all the key stakeholders who may be affected to get their feedback. For more information, detailed design standards, and case studies regarding each technique, refer to the *Rhode Island Low Impact Development Site Planning and Design Guidance Manual*.

### **GOAL: Avoid the impacts of development to natural features and pre-development hydrology.**

#### **Objective I: *Protect as much undisturbed open space as possible to maintain pre-development hydrology and allow precipitation to naturally infiltrate into the ground.***

1. Has Conservation Development been adopted to protect open space and pre-development hydrology? (This will also help to comply with objectives II and III below)
2. Has a transfer of development rights ordinance been adopted to provide an incentive for landowners to preserve natural landscapes?
3. Are limits of disturbance required to be marked on all construction plans?
4. Are there limits on lawn area for residential lots to protect undisturbed open space?
5. Are undisturbed vegetative areas required on new lots as visual screens?

#### **Objective II: *Maximize the protection of natural drainage areas, streams, surface waters, wetlands, and jurisdictional wetland buffers.***

6. Do regulations require or encourage new lots to exclude freshwater and/or coastal wetland jurisdictional areas, to the extent practicable?
7. Do regulations direct building envelopes away from steep slopes, riparian corridors, hydric soils, and floodplains, to the extent practicable?

8. Has a community buffer program been created to establish or restore a naturally vegetated buffer system along all surface waters and wetlands to supplement and expand upon the minimum requirements of the DEM and CRMC programs, where applicable?
9. Are zoning setback distances flexible in residential districts to avoid requiring house lot locations to be unnecessarily close to surface waters, wetlands, and riparian corridors?

**Objective III: *Minimize land disturbance, including clearing and grading, and avoid areas susceptible to erosion and sediment loss.***

10. Has your community adopted an erosion and sedimentation control ordinance?
11. Did your community adopt a grading ordinance to require applicants to maintain as much natural vegetation as possible and limit clearing, grading and land-disturbing activities to the minimum needed for construction maintenance and emergency services?
12. Has your community adopted a forest cover, tree protection, or tree canopy ordinance?
13. Do you require permits before removing trees on new or redevelopment sites?
14. Have minimum tree preservation standards been established for new development?
15. Do capital improvement plans include tree planting as part of project budgets?
16. Do you require that public trees removed or damaged during construction be replaced with an equivalent amount of tree diameter? (For example, if a 24 inch-diameter tree is removed it should be replaced with six four inch-diameter trees.)

**Objective IV: *Minimize soil compaction and restore soils compacted as a result of construction activities or prior development.***

17. Have you adopted provisions within land development regulations that prohibit the compaction of soils in areas needed for stormwater recharge?
18. Have you adopted requirements for construction site inspections to ensure that soils are not compacted?

**GOAL: Reduce the impacts of land alteration to decrease stormwater volume, increase groundwater recharge and minimize pollutant loadings from a site.**

**Objective V: *Provide low-maintenance, native vegetation that encourages retention and minimizes the use of lawns, fertilizers, and pesticides.***

19. Have LID landscaping standards been adopted that require the preservation of

as much natural vegetation as possible and encourage low-maintenance native landscaping?

**Objective VI: *Minimize impervious surfaces.***

20. Did your community adopt compact growth ordinances such as conservation development, planned development or mixed-use development?
21. Has your community identified growth centers where increased density is appropriate and encouraged?
22. Are residential streets required to be as narrow as possible to accommodate traffic volumes without compromising safety?
  - A. Do you require road widths of 22 feet or less for subdivisions of 40 or fewer homes or average daily trips less than 400?
  - B. Do you require road widths of 26 feet or less for subdivisions of 40-200 homes or average daily trips of 400-2,000?
23. Are street right-of-way widths allowed to be less than 45 feet?
24. Are driveway lengths and widths required to be reduced to the extent possible with pervious surfaces and shared driveways encouraged wherever appropriate?
  - A. Do you require driveways to be nine feet or less (one lane) and 18 feet or less (two lanes)?
  - B. Do you allow pervious surfaces to be used for residential driveways?
  - C. Do you allow shared driveways to be used in residential developments?
25. Do you allow the flexibility with curbs in residential streets to encourage side-of-the-road drainage into vegetated open swales, where possible?
26. Where curbs are needed, do you allow openings in curbs that allow runoff to flow into swales?
27. Have flexible sidewalk design standards been adopted that limit impervious cover?
  - A. Is the minimum sidewalk width four feet or less?
  - B. Do you require sidewalks on one side of the street only in low-density neighborhoods?
  - C. Are sidewalks required to be gently sloped so that they drain into the front yard rather than the street?
  - D. Can alternative pedestrian access such as trails or unpaved footpaths be used



instead of sidewalks?

- E. Can pervious surfaces be used for sidewalks?
28. Did your community modify the dimension, design, and surface material of cul-de-sacs to reduce total impervious cover?
- A. Is the minimum radius allowed for cul-de-sacs less than 45 feet?
  - B. Can a landscaped island or native vegetation be within the cul-de-sac?
  - C. Are alternative turnarounds allowed such as hammerheads or tees?
29. Have both minimum and maximum parking ratios been adopted to provide adequate parking while reducing excess impervious cover?
30. Do you allow pervious materials to be used for parking areas or overflow parking?
31. Are parking ratios reduced if the site is served by mass transit or has good pedestrian access?
32. Is shared parking encouraged and implemented wherever feasible in order to reduce total impervious cover?
33. Do off-site parking allowances exist to accommodate redevelopment and mixed use compact growth?
34. Are parking stalls and aisles reduced to the extent feasible in order to decrease total impervious cover?
- A. Are the minimum stall dimensions nine feet wide by 18 feet long?
  - B. Is 20% or more of the parking lot required to have smaller dimensions (eight feet by 16 feet) for compact cars?
35. Are parking lot landscaping requirements flexible and do they encourage LID techniques?
- A. Do parking lots of ten or more spaces require that 10% of the parking lot area be dedicated to landscaped areas that can include LID stormwater practices?
  - B. Is landscaping required within parking areas to “break up” pavement at fixed intervals?
  - C. Is 25-30% tree canopy coverage over on-site parking lots required?
36. Have impervious cover limits been adopted to reduce impervious cover on a community or partial-community basis?

**GOAL: Manage the Impacts at the Source.**

**Objective VII: *Infiltrate precipitation as close as possible to the point it reaches the ground using vegetated conveyance and treatment systems.***

37. Have you amended regulations to require all development projects comply with LID pursuant to the Rhode Island Stormwater Design and Installation Standards Manual?
38. Have you revised regulations to allow and encourage LID vegetated treatment systems such as bioretention, swales and filter strips to promote recharge and the treatment of runoff?

**Objective VIII: *Break up or disconnect the flow of runoff over impervious surfaces.***

39. Have you amended regulations to encourage runoff to be diverted over pervious surfaces to foster infiltration, runoff reduction and pollutant removal, where appropriate?

**Objective IX: *Provide source controls to prevent or minimize pollutants in stormwater. (Refer to Appendix G in the Rhode Island Stormwater Design and Installation Standards Manual for further information on source controls.)***

40. Do you encourage or require appropriate pet waste disposal to prevent pet waste from entering stormwater runoff?
41. Are commercial and industrial developments required to sweep their impervious areas on an annual basis?
42. Is street sweeping done regularly on community streets to limit pollutant transport to water bodies and reduce maintenance of catch basins?
43. Are community road salt storage piles covered?
44. Has a community waste water management district been adopted to encourage or require all septic systems to be inspected and maintained regularly?
45. Have you adopted a stormwater utility district to manage the existing impacts of stormwater runoff?

**Objective X: *Re-vegetate previously cleared areas to help restore groundwater recharge and pollutant removal.***

46. Have regulations been adopted to encourage re-vegetation with native species, where possible?

**Bonus:**

47. Did you revise your comprehensive plan to include the three goals and ten objectives above?



## Appendix B Incorporating LID into the Local Land Use Regulations

All of the tools provided in the *Rhode Island Low Impact Development Site Planning and Design Guidance Manual* can be implemented through changes to local land use regulations. In Rhode Island, the most effective way to start implementing these changes is to begin with the local Comprehensive Plan, as RIGL 45-22.2 requires local standards to be consistent with this document. The following Appendix is organized by the three goals and ten objectives that are required by the *Rhode Island Stormwater Design and Installation Standards Manual*. The Appendix provides model language that could be easily inserted into the Land Use or Natural Resources element of the Comprehensive Plan. Depending on the tools a given community may adopt, these provisions will provide a strong nexus between the Comprehensive Plan and future amendments to zoning or land development and subdivision regulations.

Most municipalities are regulated under the Rhode Island Pollutant Discharge Elimination System (RIPDES) Municipal Separate Storm Sewer System (MS4) program and are required by their MS4 permits to address impacts from stormwater. The MS4 program requirements are currently under review and are expected to require that MS4s select and require implementation of LID site planning and design techniques from the *Rhode Island Low Impact Development Site Planning and Design Guidance Manual*. MS4s are encouraged to consult the RIPDES MS4 Program regulations and MS4 Permit for current requirements.

### **GOAL: Avoid the impacts of development to natural features and pre-development hydrology.**

#### **Objective I: *Protect as much undisturbed open space as possible to maintain pre-development hydrology and allow precipitation to naturally infiltrate into the ground.***

Action 1.1 Adopt a Conservation Development Ordinance to protect open space and predevelopment hydrology for new subdivisions.

Or

Action 1.1 Continue to encourage the existing Conservation Development ordinance to ensure that the future growth protects as much undisturbed open space and predevelopment hydrology as possible.

Action 1.2 Require that limits of disturbance are clearly identified as part of any development plan submittal to minimize the loss of open space.

#### **Objective II: *Maximize the protection of natural drainage areas, streams, surface waters, wetlands, and jurisdictional wetland buffers.***

Action 2.1 Amend regulations to require that new lots are created out of freshwater

and/or coastal wetland jurisdictional areas, to the extent practicable.

Action 2.2 Revise regulations to direct building envelopes away from steep slopes, riparian corridors, hydric soils, and floodplains, to the extent practicable.

Action 2.3 Develop a community buffer program to establish a naturally vegetated buffer system along all streams and wetlands to supplement and expand upon the minimum requirements of the DEM and CRMC programs, where applicable.

**Objective III: *Minimize land disturbance, including clearing and grading, and avoid areas susceptible to erosion and sediment loss.***

Action 3.1 Adopt or continue to enforce an erosion and sedimentation control ordinance that addresses all land development activities.

Action 3.2 Adopt a grading ordinance to require applicants to maintain as much natural vegetation as possible and limit clearing, grading and land disturbing activities to the minimum needed for construction maintenance and emergency services.

Action 3.3 Adopt provisions in the Zoning Ordinance and/or Subdivision Regulations for preserving forest cover, protecting significant trees, and providing adequate tree canopy in developed areas.

**Objective IV: *Minimize soil compaction and restore soils compacted as a result of construction activities or prior development.***

Action 4.1 Adopt provisions within land development regulations that prohibit the compaction of soils in areas needed for post-construction stormwater recharge.

Action 4.2 Adopt provisions that allow for the regular inspection of site construction practices by the Town to ensure that soils are properly preserved and restored.

**GOAL: Reduce the impacts of land alteration to decrease stormwater volume, increase groundwater recharge and minimize pollutant loadings from a site.**

**Objective V: *Provide low-maintenance, native vegetation that encourages retention and minimizes the use of lawns, fertilizers, and pesticides.***

Action 5.1 Adopt landscaping standards that require the preservation of as much natural vegetation as possible and encourage low-maintenance native landscaping.

Action 5.2 Prohibit the installation of any plant species that may be found on the most recent listing of invasive species as published by the Rhode Island Invasive Species Council.

**Objective VI: *Minimize impervious surfaces.***

Action 6.1 Adopt compact growth ordinances such as Conservation Development,



mixed use, or planned development to minimize impervious surfaces.

Action 6.2 Tailor street width standards to be as narrow as possible while providing adequate circulation for projected traffic volumes.

Action 6.3 Require street right-of-way widths to be the minimum width needed to safely accommodate travel lanes, pedestrians and vegetated open swales.

Action 6.4 Require driveway lengths and widths to be reduced to the extent possible and encourage shared driveways and the use of pervious surfaces wherever appropriate.

Action 6.5 Revise residential street design to limit or eliminate the use of curbing where possible to allow side of the road drainage into vegetated open swales.

Action 6.6 Adopt flexible sidewalk design standards that help to balance limits on impervious cover with pedestrian needs.

Action 6.7 Modify the requirements for dimension, design, and surface material of cul-de-sacs to reduce total impervious cover and provide greater design flexibility.

Action 6.8 Adopt both minimum and maximum parking ratios to provide adequate parking while reducing excess impervious cover.

Action 6.9 Adopt innovative parking design standards that allow for reductions in parking stall and travel lane width.

Action 6.10 Encourage shared parking wherever feasible in order to reduce total impervious cover.

Action 6.11 Allow off-site parking to accommodate re-development and mixed use compact growth.

Action 6.12 Revise parking lot landscaping requirements to be flexible and encourage LID techniques.

Action 6.13 Examine the feasibility of adopting impervious cover limits for the entire community or for specific watersheds.

Action 6.14 Develop impervious cover estimates for the community and all watersheds and subwatersheds within the community using readily available RIGIS data.

## **GOAL: Manage the Impacts at the Source.**

### ***Objective VII: Infiltrate precipitation as close as possible to the point it reaches the ground using vegetated conveyance and treatment systems.***

Action 7.1 Amend regulations to require all development projects to comply with the *Rhode Island Stormwater Design and Installation Standards Manual*, as amended.

Action 7.2 Revise regulations to allow and encourage LID vegetated treatment systems, such as bioretention, swales and filter strips, to promote recharge and treatment of runoff.

**Objective VIII: *Break up or disconnect the flow of runoff over impervious surfaces.***

Action 8.1 Amend regulations to encourage runoff to be diverted over pervious surfaces to foster infiltration, runoff reduction and pollutant removal, where appropriate.

**Objective IX: *Provide source controls to prevent or minimize pollutants in stormwater (Refer to Appendix G in the Rhode Island Stormwater Design and Installation Standards Manual for further information on source controls).***

Action 9.1 Revise regulations to encourage or require appropriate pet waste disposal to prevent pet waste from entering stormwater runoff.

Action 9.2 Require commercial and industrial development to sweep their parking areas on an annual basis.

Action 9.3 Street sweeping should be done on community streets to limit pollutant transport to water bodies and reduce maintenance of catch basins.

Action 9.4 Salt storage piles should be covered.

Action 9.5 Consider adopting a waste water management district to encourage or require all septic systems to be inspected and maintained regularly.

Action 9.6 Revise regulations to limit lawn areas and encourage alternative ground covers that require less irrigation and fertilization, where possible.

Action 9.7 Consider adopting a stormwater utility district to manage the existing impacts of stormwater runoff.

**Objective X: *Re-vegetate previously cleared areas to help restore groundwater recharge and pollutant removal.***

Action 10.1 Revise regulations to encourage re-vegetation with native species, where possible.

